

General Catalogue

50Hz

SHIMGE PUMP INDUSTRY (ZHEJIANG) CO., LTD.



Immediately join the Shimge Family by scanning:
<https://www.shimgepump.com>

SHIMGE PUMP INDUSTRY (ZHEJIANG) CO., LTD.

Add: Dayangcheng Industrial Zone, Daxi Town, Wenling City, Zhejiang Province, China
Tel: +86-576-86339960
Fax: +86-576-86337079
Email: admin@shimge.com

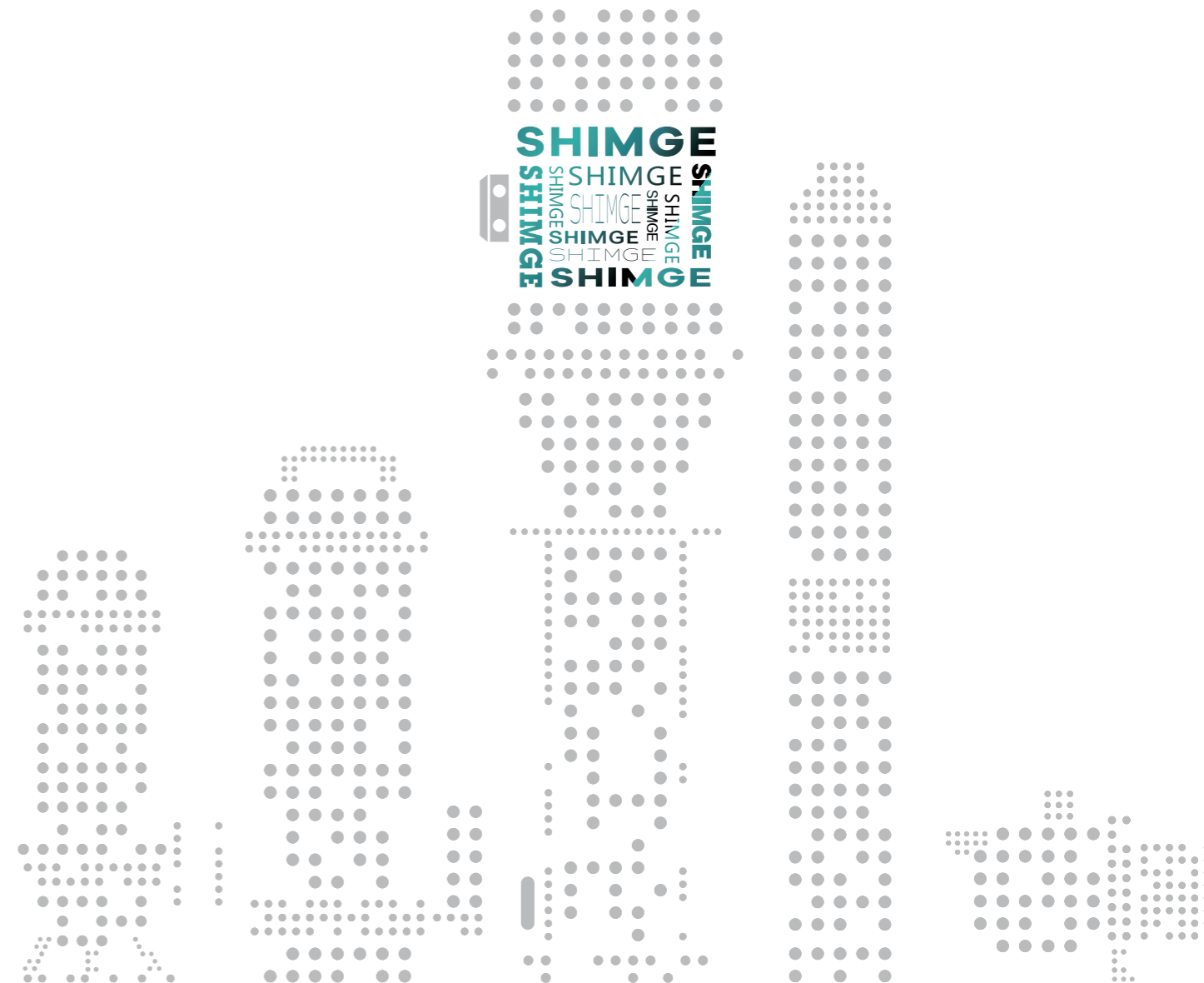

CATALOG

Peripheral Pumps

QB  **01**

Self-Priming Peripheral Pumps

WZB  **02**

Automatic Self-Priming Peripheral Pumps

PW  **03**

PW-Z  **04**

PW-F  **05**

PZ  **06**

Centrifugal Pumps

CPm  **07**

SHF(m)  **08**

2SGP(m)  **09**

SGT  **10**

PXm  **11**

PX-E  **12**

PRm  **13**

KSW  **14**

PUM  **15**

CA  **16**

Self-Priming JET Pumps











JET  **17**



SGJW-S  **18**

JET-G2  **19**







PJ750M  **20**

Submersible Pump for Deep Well

2.5SGm		22
3SGm		24
3SPm		26
3SEm-T		28
3.5SEm-T		30
4SG(m)		32
4SP(m)		36
4SE(m)-T		39
4SS(m)		44
6SE-T		46



6SS		48
NK(m)		50
4P		51

Submersible pump & sewage pump

QDX-L		52
QDX-K3		54
QDX-T		56
QD		57
Q(D)Y-K2		59
QY		61









WVSD		64
WQK		65
WQ(D)-L1		66
WQD		69
WQ		71
WQ-QG		72

Stainless Steel Multi-Stage Centrifugal Pump

BL/BLT		74
BW/BWJ		81
BWI		84
BWE/BLE		85

PLD		89
-----	---	----

Circulation Pump

APM		91
APF		92
BPS		93
XPS		94
XP		96
ZP/ZPS		97
XPH		98
CPHB/CPH		99
HBS-12		101



Company Profile

Established in 1984 and headquartered in Daxi Town, Wenling City, Zhejiang Province—a town with flourishing pump industry, Shimge Pump Industry (Zhejiang) Co., Ltd. is a limited liability company specialized in producing various kinds of pumps and control equipment. For over three decades, Shimge Pump Industry has been committed to technical researches, manufacturing and marketing of all kinds of pumps and control equipment, as well as providing first-class pumps and water treatment system solutions for the world.

Based on keen market insight, the company developed the “screw pump” in 1987, which filled the gap in the domestic market at that time. Due to its excellent quality, Shimge soon stood out in the industry, and started its journey as a legendary brand in China’s pump industry. The company was once successfully listed in the A-share market in Shenzhen Stock Exchange on December 31, 2010 (stock code: 002532. According to the development strategy of the company, it was delisted in the form of asset reorganization and completed privatization in July 2020`). Currently, the company has 6 major brands, 12 product series with more than 2,000 specifications, and 8 holding subsidiaries, becoming a real leading brand in China’s pump industry.



Shimge's production base in HangZhou, Zhejiang Province



Shimge's casting parts production base in JiangSu Province

Shimge's casting production base in JiangXi Province

Shimge's casting production base in JiangSu Province



Shimge's production base in SanChiku, Wenling, Zhejiang Province



High Quality Production

FOR BETTER LIFE

Shimge sticks on the comprehensive innovation on R&D and production process which commits to improve the production process and efficiency.



On one hand, we strengthen the professional skill of workers by sustaining training, and on the other, we put into the robot automatic production machine instead of manual work. By those ways, we have not only reduced the manufacturing cost, but also improved the product quality and stability.

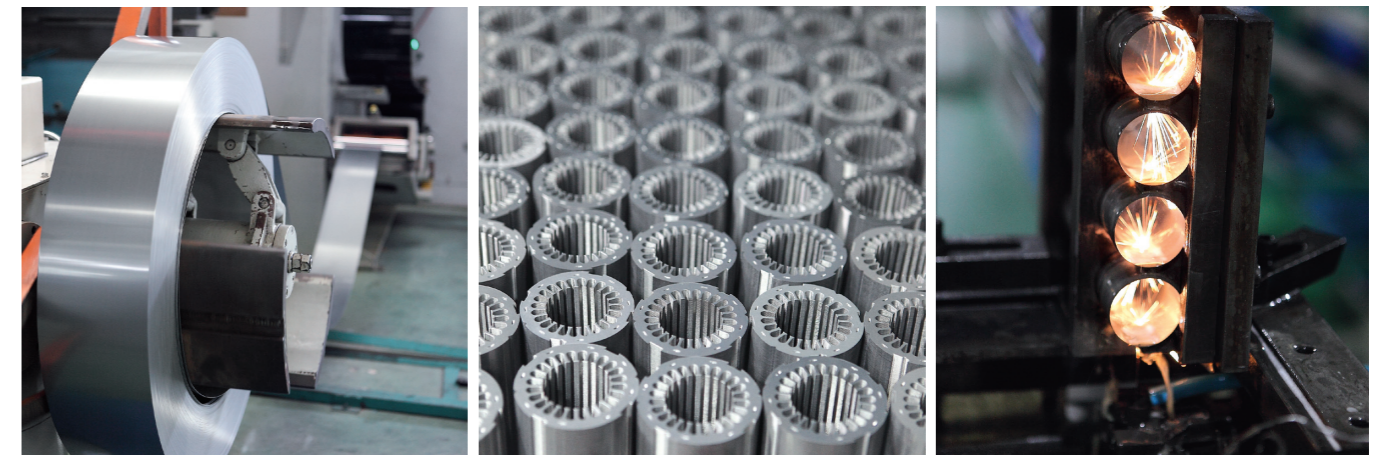

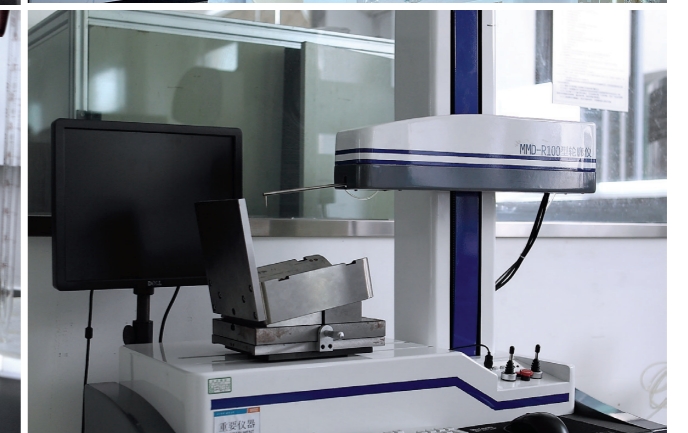

Strict Quality Control

FOR BETTER LIFE

Since its establishment, Shimge has always actively promoted comprehensive “lean” quality and environment management, and has currently passed ISO9001, ISO14001 and OHSAS18001 certification, introduced excellent performance management in line with GB/T 19580 and established a sound quality assurance system.



SHIMGE has equipped an industry-leading physicochemical testing center, and its delivery performance inspection platform has reached a precision of grade B (grade 1) in the evaluation conducted by an authoritative agency. In addition, its products have passed GS, CE and UL certification, and met the specifications of the RoHS Directive.

QB

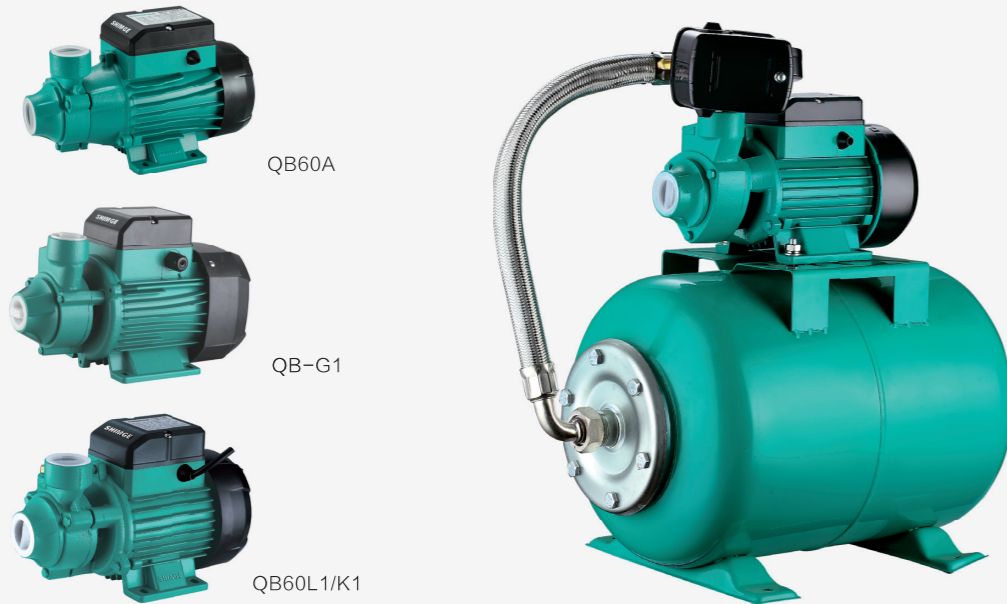

WZB



Application Limits

- Suction head up to 8m
- Liquid temperature up to +40°C
- Ambient temperature up to +40°C
- Max. Working pressure: 6bar
- Voltage fluctuation should not exceed 10% of rated value.
- pH: 6.5 to 8.5

Advantages & Features

- Small size,high pressure
- Easy installation & maintenance

Application Limits

- Suction head up to 8m
- Ambient temperature up to +40°C
- Max. Working pressure: 6bar
- Voltage fluctuation should not exceed 10% of rated value.
- pH: 6.5 to 8.5

Advantages & Features

- Self-priming pump
- Bulid-in one-way valve
- Add the impeller axial direction contact surface, stainless steel 304 inserts

Performance Data

Model	Power		Max. Flow (m³/h)	Max. Head (m)	Head Range (m)	Max. Suction (m)	Packing Dim. L × W × H(mm)	G.W (kg)	20'Loading Qty. (pcs)
	kW	HP							
QB60G1	0.37	0.5	2.4	33	1~27	8	280 × 155 × 185	4.8	3060
QB70G1	0.55	0.75	3	48	1.5~44	8	235 × 135 × 175	4.3	4320
QB80G1	0.75	1	3.6	60	2.5~53	8	235 × 135 × 175	4.7	4320
QB60L1	0.37	0.5	2.4	33	1~27	8	315 × 190 × 207	8.3	2100
QB60K1	0.37	0.5	2.4	40	1.5~30	8	315 × 190 × 207	9.9	2000
QB60A	0.37	0.5	2.4	33	1~27	8	270 × 145 × 177	4.5	3540

Note:The length of cable is 0.3M,no plug.

Performance Data

Model		Power		Max. Flow (m³/h)	Max. Head (m)	Head Range (m)	Max. Suction (m)	Packing Dim. L × W × H(mm)	G.W (kg)	20'Loading Qty. (pcs)
Single-Phase	Three-Phase	kW	HP							
WZB250	-	0.25	0.34	2.3	20	0~16	8	280x215x275	6.5	1728
WZB370	-	0.37	0.5	2.7	30	0~27	8	280x215x275	7.3	1728
WZB550	-	0.55	0.75	3.3	40	0~37	8	305 × 230 × 300	9.7	1330
WZB750	-	0.75	1	3.9	50	0~47	8	305 × 230 × 300	10.5	1330
WZB370T1	-	0.37	0.5	2.7	30	0~27	8	280 × 215 × 275	9.1	1728
WZB550T1	-	0.55	0.75	3.3	40	0~37	8	305 × 230 × 300	11.7	1330
WZB750T1	-	0.75	1	3.9	50	0~47	8	305 × 230 × 300	13.7	1330
1.5WZB-55K1	1.5WZBS-55K1	1.1	1.5	6	55	1~51	8	305 × 230 × 300	18.5/19	1470

Note:The length of single phase pump cable is 1.3m,Europe plug;three-phase pump no plug.

PW

PW-Z



Application Limits

- Suction lift up to 8 m
- Max. working pressure 5 bar
- Liquid temperature up to +90°C
- Ambient temperature up to +40°C
- Voltage fluctuations should not exceed 10% of rate value

Advantages & Features

- Compact design, easy installation
- A simple Pressure switch control automatically
- Pump body insert of stainless sheet 304
- Shaft extension is stainless steel 304
- The impeller of copper alloy
- High quality mechanical seal

Application Limits

- Suction lift up to 8 m
- Max. working pressure 5 bar
- Liquid temperature up to +90°C
- Ambient temperature up to +40°C
- Voltage fluctuations should not exceed 10% of rate value

Advantages & Features

- Compact design, easy installation
- A simple Pressure switch control automatically
- Pump body insert of stainless sheet 304
- Shaft extension is stainless steel 304
- The impeller of copper alloy
- High quality mechanical seal

Performance Data

Model	Power		Max. Flow (m³/h)	Max. Head (m)	Head Range (m)	Max. Suction (m)	Packing Dim. L × W × H(mm)	G.W (kg)	20'Loading Qty. (pcs)
	kW	HP							
PW125	0.125	0.17	2.0	24	1~20	8	295 × 230 × 300	8.3	1600
PW250	0.25	0.34	2.2	30	1~26	8	295 × 230 × 300	9.0	1600
PW370	0.37	0.5	2.4	36	1~32	8	295 × 230 × 300	9.3	1600
PW550	0.55	0.75	3.0	42	1.5~38	8	315 × 245 × 325	12.1	1320
PW750	0.75	1	3.4	50	1.5~46	8	315 × 245 × 325	13.8	1320
PW1100	1.1	1.5	6.0	55	1.5~51	8	365 × 280 × 380	21.7	720
PW1100L	1.1	1.5	6.0	55	1.5~51	8	515 × 320 × 640	26.3	260

Performance Data

Model	Power		Max. Flow (m³/h)	Max. Head (m)	Head Range (m)	Max. Suction (m)	Packing Dim. L × W × H(mm)	G.W (kg)	20'Loading Qty. (pcs)
	kW	HP							
PW125Z	0.125	0.17	2	24	1~20	8	295 × 230 × 300	8.3	1600
PW250Z	0.25	0.34	2.2	30	1~26	8	295 × 230 × 300	9.0	1600
PW370Z	0.37	0.5	2.4	36	1~32	8	295 × 230 × 300	9.3	1600
PW550Z	0.55	0.75	3	42	1.5~38	8	315 × 245 × 325	12.1	1320
PW750Z	0.75	1	3.4	50	1.5~46	8	315 × 245 × 325	13.8	1320
PW1100Z	1.1	1.5	6	55	1.5~51	8	365 × 280 × 380	21.7	720
PW1100ZL	1.1	1.5	6	55	1.5~51	8	515 × 320 × 640	26.3	260

Note: The cable length of single phase pump is 1.3m, Europe plug.

Note: The cable length of single phase pump is 1.3m, Europe plug.

PW-F



Application Limits

- Suction lift up to 8 m
- Max. working pressure 5 bar
- Liquid temperature up to +90°C
- Ambient temperature up to +40°C
- Voltage fluctuations should not exceed 10% of rate value

Advantages & Features

- Compact design, easy installation
- Pressure and flow switch control automatically
- Pump body insert of stainless sheet 304
- Shaft extension is stainless steel 304
- Intelligent control: The pump equips with flow switch, pressure sensor, control panel, collecting the flow and pressure data by flow switch and pressure sensor. Through the water flow and water pressure data collected by flow switch and pressure switch, electronic unit control the pump running/stop, solve the frequently starting problems under low water flow, and completely inhibit frequently starting if water flows lower than 0.3m³/h.
- Pressure sensing function: No need to adjust the pressure, pump can create start-up pressure according to the pipe pressure.
- Time delay start: 3-seconds delay on startup to prevent electric transient surge
- Dry-Run protection: Pump shut down if no water flows past pump inlet after running 6 minutes, when there is water flow past pump inlet, pump restart.
- Scale prevention: Pump will automatically run 10 seconds for scale prevention once per 3 days among outage period.

Performance Data

Model	Power		Max. Flow (m ³ /h)	Max. Head (m)	Head Range (m)	Max. Suction (m)	Packing Dim. L × W × H (mm)	G.W (kg)	20' Loading Qty. (pcs)
	kW	HP							
PW125F	0.125	0.17	2.0	24	0~20	8	295 × 230 × 300	8.3	1600
PW250F	0.25	0.34	2.2	30	0~26	8	295 × 230 × 300	9.0	1600
PW370F	0.37	0.5	2.4	36	0~32	8	295 × 230 × 300	9.3	1600
PW550F	0.55	0.75	3.0	42	0~38	8	315 × 245 × 325	12.1	1320
PW750F	0.75	1	3.4	50	0~46	8	315 × 245 × 325	13.8	1320

PZ



Application Limits

- Medium temperature: No higher than 60°C
- Ambient temperature: No higher than 40°C
- Pump body Max. Pressure: 0.5Mpa
- The PH value of the medium is between 6.5 and 8.5, the volume ratio of solid impurities in the medium is ≤ 0.1%, and the particle size is ≤ 0.2mm.
- Voltage fluctuation: No more than ± 10% of the rating.

Advantages & Features

- Pump body/ Coupling: HT200;
- Shaft: 304+45#;
- Motor casing/End cover: YL102;
- Mechanical seal: S:A (PC) High temperature nitrile rubber
- Bearing: C&U;
- Motor: 2-stages asynchronous motor, copper coil, with thermal protector, continuous operation;
- Level of protection: IPX4;
- Insulation grade: F. External temperature protector on the pump body.

Performance Data

Model	Power		Max. Flow (m ³ /h)	Max. Head (m)	Head Range (m)	Max. Suction (m)	Packing Dim. L × W × H (mm)	G.W (kg)	20' Loading Qty. (pcs)
	kW	HP							
PZ125	0.125	0.17	2.1	24	0~20	6	330 × 300 × 310	10.9	884
PZ250	0.25	0.34	2.4	28	0~24	6	330 × 300 × 310	11.7	884
PZ370	0.37	0.5	2.7	32	0~28	6	330 × 300 × 310	12.2	884
PZ550	0.55	0.75	3.3	38	0~34	6	370 × 340 × 255	15	627
PZ750	0.75	1	3.6	44	0~40	6	370 × 340 × 255	15.9	627

CPm



SHF(m)



SHF20A/SHF30A



SHFm5AM/SGAm1A

Application Limits

- Suction head up to 7m
- Liquid temperature up to +40°C
- Ambient temperature up to +40°C
- Max. Working pressure: 6bar
- Voltage fluctuation should not exceed 10% of rated value.
- pH: 6.5 to 8.5

Advantages & Features

- Single suction centrifugal pump, with high efficiency
- Copper impeller, stable performance
- High head, small flow rate

Performance Data

Model	Power		Max. Flow (m³/h)	Max. Head (m)	Head Range (m)	Max. Suction (m)	Packing Dim. L × W × H(mm)	G.W (kg)	20'Loading Qty. (pcs)
	Single-Phase kW	HP							
CPm370	0.37	0.5	6	22	8~22	7	300 × 205 × 270	8.6	1672
CPm550	0.55	0.75	6.6	26	11~26	7	330 × 225 × 285	11.8	1456
CPm750	0.75	1	7.2	32	14~32	7	330 × 230 × 300	13.8	1225
CPm170	0.55	0.75	7.8	40	17~40	7	390 × 240 × 290	21	1168
CPm190	0.75	1	7.8	48	20~48	7	390 × 260 × 320	24.5	981
CPm200	0.75	1	8.4	55	20~55	7	455 × 280 × 340	33.5	742

Note: The length of cable is 0.3m, no plug.

Application Limits

- Suction head up to 7m
- Liquid temperature up to +40°C
- Ambient temperature up to +40°C
- Max. Working pressure: 3bar
- Voltage fluctuation should not exceed 10% of rated value.
- pH: 6.5 to 8.5

Advantages & Features

- Large flow, high efficiency
- Compact structure, easy to install

Performance Data

Model		Power		Max. Flow (m³/h)	Max. Head (m)	Head Range (m)	Max. Suction (m)	Packing Dim. L × W × H(mm)	G.W (kg)		20'Loading Qty. (pcs)
Single-Phase	Three-Phase	kW	HP						Single-Phase	Three-Phase	
SGAm1B	-	0.55	0.75	18	14	8~14	7	350 × 235 × 255	12	-	1520
SGAm1A	-	0.75	1	18	17	11~17	7	350 × 235 × 255	11	-	1520
SHFm5B	-	0.75	1	30	11	6~11	7	365 × 240 × 265	14.5	-	1386
SHFm5A	-	1.1	1.5	30	14	8~14	7	365 × 240 × 265	13.5	-	1386
SHFm5BM	-	1.1	1.5	36	20.2	7~20.2	7	425 × 250 × 295	22.5	24.5	1024
SHFm5AM	SHF5AM	1.5	2	36	22.5	10~22.5	7	425 × 250 × 295	20.5	-	1024
SHFm6AM	-	2.2	3	83	16.5	6~16.5	7	510 × 295 × 355	37.5	-	584
SHFm6C	-	1.1	1.5	66	11.9	6~11.9	7	510 × 295 × 355	37	35	584
SHFm6B	-	1.5	2	72	14.7	6~14.7	7	460 × 285 × 345	31	-	695
SHFm6A	SHF6A	2.2	3	78	18.5	8~18.5	7	460 × 285 × 345	28.5	-	695
SHFm6CR	-	1.1	1.5	66	11.9	6~11.9	7	510 × 295 × 355	39	39	584
SHFm6BR	-	1.5	2	72	14.7	6~14.7	7	460 × 285 × 345	30.5	-	695
SHFm6AR	SHF6AR	2.2	3	78	18.5	8~18.5	7	460 × 285 × 345	28.5	-	695
-	SHF20B	3	4	114	16.5	10~16.5	7	560 × 290 × 385	-	46	400
-	SHF20A	4	5.5	129	19.5	11~19.5	7	560 × 290 × 385	-	50	400
-	SHF30B	5.5	7.5	125	20	13~20	7	590 × 340 × 430	-	66	350
-	SHF30A	7.5	10	140	24.5	17~24.5	7	640 × 340 × 430	-	80	300

Note: The length of cable is 0.3m, The cable length of three-phase pump SHF5AM, SHF6A, SHF6AR are 0.3m; no plug. The rest of the model without cable

2SGP(m)

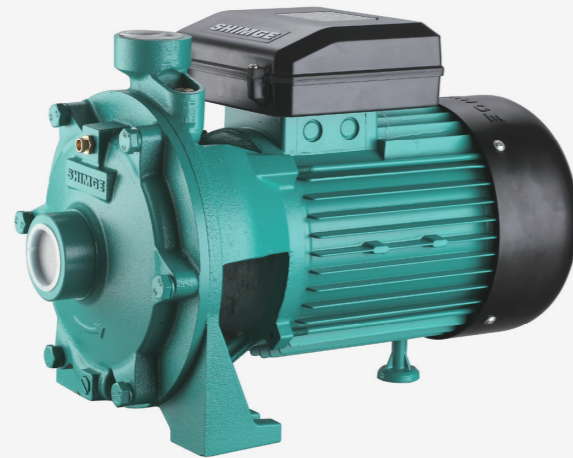

SGT

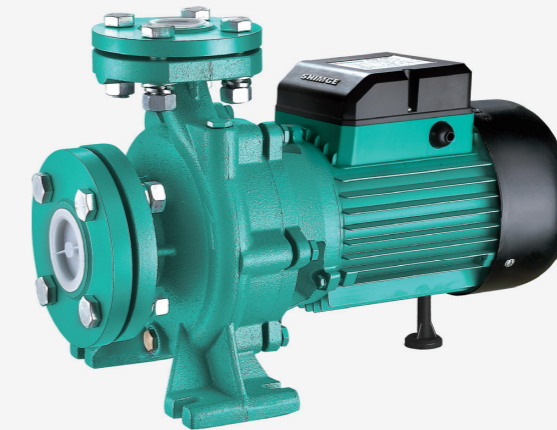

Application Limits

- Suction head up to 8m
- Liquid temperature up to +40°C
- Ambient temperature up to +40°C
- Max. Working pressure: 5bar
- Voltage fluctuation should not exceed 10% of rated value.
- pH: 6.5 to 8.5

Advantages & Features

- Double impeller centrifugal pump, satisfies the requirement of high head.
- Compact structure

Performance Data

Model	Power		Max. Flow (m³/h)	Max. Head (m)	Head Range (m)	Max. Suction (m)	Packing Dim. L × W × H(mm)	G.W (kg)	20'Loading Qty. (pcs)
	kW	HP							
2SGPm25/130	0.75	1	6	42	7~42	8	400 × 250 × 295	17	1270
2SGPm25/140	1.1	1.5	10.2	42	17~42	8	460 × 270 × 315	24	885
2SGPm25/160B	1.5	2	12	50	22~50	8	460 × 270 × 315	27	885
2SGPm32/160A	2.2	3	13	60	28~50	8	490 × 300 × 355	31.6	584

Note: The length of cable is 0.3m, no plug.

Application Limits

- Suction head up to 7m
- Liquid temperature up to +40°C
- Ambient temperature up to +40°C
- Max. Working pressure: 7bar
- Voltage fluctuation should not exceed 10% of rated value.
- pH: 6.5 to 8.5

Advantages & Features

- Standard flange centrifugal pump
- Large flow, high efficiency

Performance Data

Model	Power		Max. Flow (m³/h)	Max. Head (m)	Head Range (m)	Max. Suction (m)	Packing Dim. L × W × H(mm)	G.W (kg)	20'Loading Qty. (pcs)
	kW	HP							
SGT32-160/1.5	1.5	2	21	21	10~21	8	490 × 285 × 355	35	616
SGT32-160/2.2	2.2	3	21	28	14~28	8	520 × 285 × 355	40	568
SGT32-160/3	3	4	21	35	16~35	8	565 × 275 × 390	43	556
SGT32-200/4	4	5.5	21	45	7~45	8	590 × 325 × 440	57	371
SGT32-200/5.5	5.5	7.5	21	58	8~58	8	610 × 325 × 440	68.5	336
SGT32-200/7.5	7.5	10	21	70	10~70	8	660 × 325 × 440	79	336
SGT40-125/1.5	1.5	2	24	18	7~18	8	490 × 255 × 315	34	774
SGT40-125/2.2	2.2	3	24	24	9~24	8	520 × 255 × 315	40	738
SGT40-160/3	3	4	30	28	6~28	8	565 × 275 × 390	48	480
SGT40-160/4	4	5.5	30	36	17~36	8	590 × 275 × 390	51	456
SGT40-200/5.5	5.5	7.5	39	42	10~42	8	610 × 325 × 440	68.5	350
SGT40-200/7.5	7.5	10	39	52	11~52	8	680 × 300 × 440	83.5	324
SGT80-125A/7.5	7.5	10	120	23	10~23	7	700 × 300 × 450	84.5	285

PXM



PXM

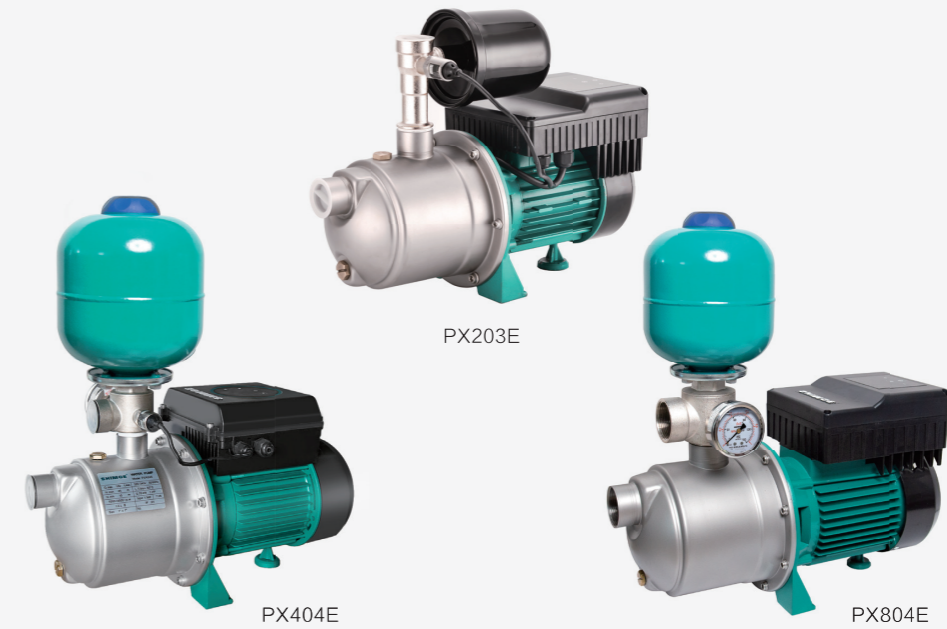

Application Limits

- Suction head up to 7m
- Liquid temperature up to +40°C
- Ambient temperature up to +40°C
- Max. Working pressure: 4.8bar
- Voltage fluctuation should not exceed 10% of rated value.
- pH: 6.5 to 8.5

Advantages & Features

- Suitable for transferring water without abrasive particles or other liquid whose properties are similar to water.
- Widely used in garden irrigation, vegetable greenhouse water supply, breeding industry water supply and drainage, various corollary equipment, etc.

Performance Data

Model		Power		Max. Flow (m³/h)	Max. Head (m)	Head Range (m)	Max. Suction (m)	Packing Dim. L × W × H(mm)	G.W (kg)	20'Loading Qty. (pcs)
Single-Phase	Three-Phase	kW	HP							
PXm203	PX203	0.46	0.6	5	32	4~32	7	460 × 225 × 255	10.5	1195
PXm204	PX204	0.55	0.75	5.4	44	4~44	7	460 × 225 × 255	11	1195
PXm402	PX402	0.46	0.6	8	22	4~22	7	460 × 225 × 255	10.5	1195
PXm403	PX403	0.55	0.75	8.4	33.5	4~33.5	7	460 × 225 × 255	11	1195
PXm404	PX404	0.75	1	9	45	4~45	7	460 × 225 × 255	11.5	1195

Note: No plug 0.3 m.

Application Limits

- Suction head up to 7m
- Liquid temperature up to +40°C
- Ambient temperature up to +40°C
- Max. Working pressure: 4.8bar
- Voltage fluctuation should not exceed 10% of rated value.
- pH: 6.5 to 8.5

Advantages & Features

- Suitable for transferring water without abrasive particles or other liquid whose properties are similar to water.
- Widely used in garden irrigation, vegetable greenhouse water supply, breeding industry water supply and drainage, various corollary equipment, etc.

Performance Data

Model	Power		Max. Flow (m³/h)	Max. Head (m)	Head Range (m)	Max. Suction (m)	Packing Dim. L × W × H(mm)	G.W (kg)	20'Loading Qty. (pcs)
	Single-Phase	Three-Phase							
PX203E			5	32	10~30	7	390 × 195 × 320	9.5	1151
PX404E			9	45	10~40	7	450 × 235 × 475	15.3	557
PX804E			14	45	10~40	7	510 × 240 × 530	20.7	432

Note: 0.3 m, no plug

PRM



KSW

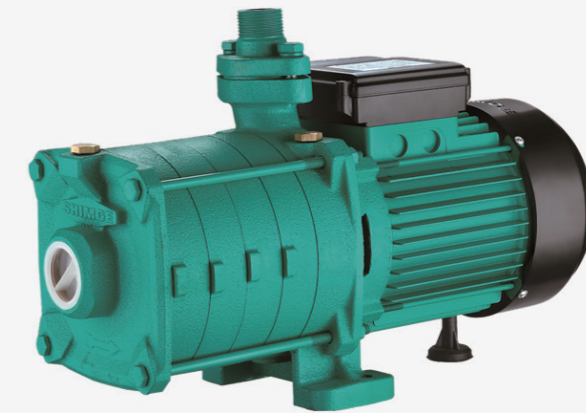

Application Limits

- Max. liquid temperature 40° C
- Max. ambient temperature 40° C
- Max. running pressure 4.5bar
- Voltage fluctuations should not ± 10% of rate value
- PH 6.5 to 8.5

Advantages & Features

- Domestic water supply
- Landscaping irrigation
- Water pressure boost

Performance Data

Model	Power		Max. Flow (m³/h)	Max. Head (m)	Head Range (m)	Max. Suction (m)	Packing Dim. L × W × H(mm)	G.W (kg)	20'Loading Qty. (pcs)
	kW	HP							
PRm202	0.31	0.4	5.4	22	4~22	7	415 × 185 × 200	9.5	1512
PRm203	0.37	0.5	5.4	34	4.5~34	7	440 × 185 × 200	10.5	1404
PRm204	0.55	0.75	5.4	45	5~45	7	465 × 185 × 200	11.5	1296
PRm402	0.55	0.75	6.5	23	10~23	8	415 × 210 × 275	12	1144
PRm403	0.75	1.02	6.5	34	12~34	8	460 × 210 × 275	13	1120
PRm404	0.9	1.22	6.5	45	15~45	8	490 × 210 × 275	13	1056
PRm405	1.1	1.5	6.5	57	20~57	8	530 × 210 × 295	17	968
PRm406	1.5	2.04	6.5	68	30~68	8	555 × 210 × 295	19.5	896

Note: The cable length is 0.3m, no plug.

Application Limits

- Max. liquid temperature: 40° C
- Max. ambient temperature: 40° C
- Max. running pressure: 5.5bar
- Voltage fluctuations should be within ± 10% of the rate value.
- PH: 6.5 to 8.5

Advantages & Features

- Domestic water supply
- Landscaping irrigation
- Water pressure boost

Performance Data

Model	Power		Max. Flow (m³/h)	Max. Head (m)	Head Range (m)	Max. Suction (m)	Packing Dim. L × W × H(mm)	G.W (kg)	20'Loading Qty. (pcs)
	kW	HP							
KSW110	0.9	1.2	5.4	55	40	7	445x360x660	35	582

Note: The cable length is 0.3m, no plug.

PUM

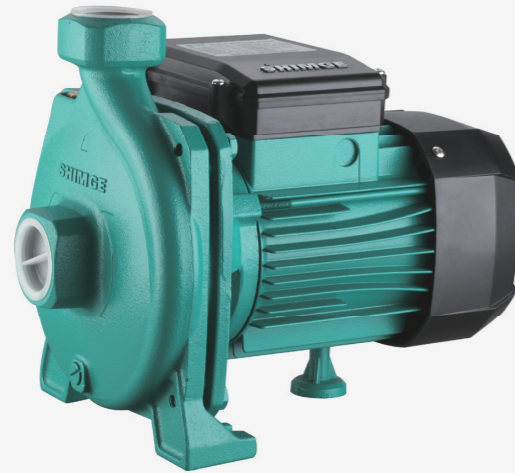

CA



CA200



CA1000

Application Limits

- Suction head up to 7m
- Liquid temperature up to +90°C
- Ambient temperature up to +40°C
- Max. Working pressure: 3bar
- Voltage fluctuation should not exceed 10% of rated value.
- pH: 6.5 to 8.5

Advantages & Features

- Stainless steel impeller, shaft 304
- Specially designed for view of the hot water circulation
- High quality mechanical seal, NSK bearing, improve the reliability of the product
- F-grade motor.

Performance Data

Model	Power		Max. Flow (m³/h)	Max. Head (m)	Head Range (m)	Max. Suction (m)	Packing Dim. L × W × H(mm)	G.W (kg)	20'Loading Qty. (pcs)
	kW	HP							
PUM200L1	0.25	0.3	5	15.5	4~15.5	7	300 × 205 × 240	7.5	1881
PUM400L1	0.37	0.5	6	22	8~22	7	330 × 210 × 285	10	1568
PUM600L1	0.55	0.75	6.6	26	11~26	7	330 × 225 × 285	12	1456
PUM751L1	0.75	1	7.2	32	14~32	7	330 × 230 × 300	14	1225
PUM750L1	0.75	1	12.6	25	4~25	7	330 × 230 × 300	14	1225

Note: The cable length of single phase pump is 1.3m, Europe plug.

Application Limits

- The pumped medium is clean water and other liquids with similar property to water;
- The temperature of medium ranges from 0° C~+60° C;
- The pH value of medium is 6.5~8.5;
- The volume ratio of solid impurities is no more than 0.1%, and the particle size is no greater than 0.2mm;
- The voltage fluctuation range is ± 10% of the rated value.

Advantages & Features

- Permanent magnet motor
- Variable frequency and constant pressure
- Simple style
- Large touch screen

Performance Data

Model	Power		Max. Flow (m³/h)	Max. Head (m)	Head Range (m)	Max. Suction (m)	Packing Dim. L × W × H(mm)	G.W (kg)	20'Loading Qty. (pcs)
	kW	HP							
CA200	0.2	0.27	3.5	25	4~25	5	275 × 168 × 228	4.8	1512
CA1000	1	1.36	7.2	50	10~45	6	408 × 260 × 205	10.5	595

JET



SGJW-S



Application Limits

- Suction head up to 9m
- Liquid temperature up to +40°C
- Ambient temperature up to +40°C
- Max. Working pressure: 5bar
- Voltage fluctuation should not exceed 10% of rated value.
- pH: 6.5 to 8.5

Advantages & Features

- The JET type self-priming pump
- High suction, with short time
- Different impeller material configuration

Application Limits

- Suction head up to 9m
- Liquid temperature up to +40°C
- Ambient temperature up to +40°C
- Max. Working pressure: 6bar
- Voltage fluctuation should not exceed 10% of rated value.
- pH: 6.5 to 8.5

Advantages & Features

- Copper impeller, stainless steel pump cover
- Pump body with installation foot set

Performance Data

Model		Power		Max. Flow (m³/h)	Max. Head (m)	Head Range (m)	Max. Suction (m)	Packing Dim. L×W×H(mm)	G.W (kg)	20'Loading Qty. (pcs)
Single-Phase	Three-Phase	kW	HP							
JET100P	--	0.75	1	4.2	46	6~46	9	430×210×195	16.5	1480
JET300	--	0.55	0.75	2.7	45	3~42	9	470×200×204	17	1606
JET400	--	0.75	1	3.9	45	7~45	9	470×200×204	17.5	1606
JET550L1	--	0.55	0.75	3.6	41	7~41	9	480×205×225	14	1420
JET750L1	--	0.75	1	4.5	41	7~41	9	480×205×225	15.5	1420
JET1100L1	--	1.1	1.5	5.4	48	6~48	9	480×205×225	16.5	1420
JET1500A	JETS1500A	1.5	2	5.4	55	4.5~55	9	555×240×265	24.5	918
JET1800A	JETS1800A	1.8	2.5	6	62	3.5~62	9	555×240×265	26	918

Note: The cable length of single phase pump JET100P~400 are 0.3m, JET550A~1800A's are 1.3m, Europe plug; three-phase cable length is 0.3m, no plug.

Performance Data

Model	Power		Max. Flow (m³/h)	Max. Head (m)	Head Range (m)	Max. Suction (m)	Packing Dim. L×W×H(mm)	G.W (kg)	20'Loading Qty. (pcs)
	Single-Phase	HP							
SGJW37S	0.37	0.5	3	32	2.5~32	8	370*165*210	8.6	2192
SGJW55S	0.55	0.75	3.6	41	3~41	9	420*200*235	13.6	1425
SGJW75S	0.75	1	4.5	45	4.5~45	9	420*200*235	14.3	1425
SGJW110S	1.1	1.5	5.4	52	5~52	9	420*200*235	15	1425

JET-G2



PJ750M



Application Limits

- Suction head up to 9m
- Liquid temperature up to +40°C
- Ambient temperature up to +40°C
- Max. Working pressure: 6bar
- Voltage fluctuation should not exceed 10% of rated value.
- pH: 6.5 to 8.5

Advantages & Features

- 304 stainless steel pressed tensile pump body & pump cover
- Hydraulic optimization design, excellent performance
- Nozzle, guide vane and the impeller PPO engineering plastics
- Products are complete in specifications, meet drinking water standards

Performance Data

Model	Power		Max. Flow (m³/h)	Max. Head (m)	Head Range (m)	Max. Suction (m)	Packing Dim. L × W × H(mm)	G.W (kg)	20'Loading Qty. (pcs)	
	Single-Phase	kW								HP
JET250G2		0.25	0.34	3.2	28	4~28	8	370*210*225	6.1	1628
JET370G2		0.37	0.5	3.6	32	5~32	7	370*210*225	6.6	1628
JET550G2		0.55	0.75	4	38	4~38	9	410*230*265	8.8	1140
JET750G2		0.75	1	4.5	44	5.5~44	9	410*230*265	10.2	1140
JET1100G2		1.1	1.5	5.4	48	9~48	9	410*245*275	12	1017
JETS250G2		0.25	0.34	3.2	28	4~28	8	370*210*225	5.6	1628
JETS370G2		0.37	0.5	3.6	32	5~32	7	370*210*225	6.1	1628
JETS550G2		0.55	0.75	4	38	4~38	9	410*230*265	8.5	1140
JETS750G2		0.75	1	4.5	44	5.5~44	9	410*230*265	9.8	1140
JETS1100G2		1.1	1.5	5.4	48	9~48	9	410*245*275	11.5	1017

Note: 3m short, no plug

Application Limits







- Medium temperature: No higher than 40°C
- Ambient temperature: No higher than 40°C
- Pump body Max. Pressure: 0.6Mpa
- The PH value of the medium is between 6.5 and 8.5, the volume ratio of solid impurities in the medium is ≤ 0.1%, and the particle size is ≤ 0.2mm.
- Voltage fluctuation: No more than ± 10% of the rating.

Advantages & Features

- Pump cover: SS304;
- Pump body: HT200;
- Guide vane: PPO;
- Shaft: 45#;
- Coupling/Motor casing/End cover: YL102;
- Mechanical seal: Ceramic / Graphite / Nitrile rubber;
- Bearing: C&U;
- Motor: 2-stages asynchronous motor, copper coil, with thermal protector, continuous operation;
- Level of protection: IP X4;
- Insulation grade: B.

Performance Data

Model	Power		Max. Flow (m³/h)	Max. Head (m)	Head Range (m)	Max. Suction (m)	Packing Dim. L × W × H(mm)	G.W (kg)	20'Loading Qty. (pcs)
	kW	HP							
PJ750M1	0.75	1	5.1	30	10~30	8	419×167×197	12	1400

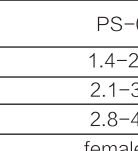
	Model	Dimension (cm)		Model	Dimension (cm)		Model	Dimension (cm)
	VC-19L	27 × 27 × 40		HC-24L	31 × 28 × 40		VCF-60L	46 × 46 × 65
	VC-24L	27 × 27 × 46		HC-36L	38 × 36 × 43		VCF-80L	46 × 46 × 76
	Model	Dimension (cm)		Model	Dimension (cm)		Model	Dimension (cm)
	VS-23L	33 × 33 × 33		HC-60L	48 × 46 × 49		VCF-100L	46 × 46 × 85
	VS-24L	36 × 36 × 34		HC-80L	48 × 46 × 60			
				Model	Dimension (cm)			
				HC-100L	48 × 46 × 68			
							Model	Connection
						3-way	1"	
						4-way	1"	
						5-way	1"	

	PS-02A	PS-02B	PS-02C
	1.4-2.8 bar	1.4-2.8 bar	1.4-2.8 bar
	2.1-3.5bar	2.1-3.5bar	female/male
	2.8-4.3bar	2.8-4.3bar	
	female/male	3.5-5.6bar	
		4.9-7.2bar	
		female/male	

	Model	PG-P	PG-SS	PG-S
	SIZE			
	40mm	PG-40	PG-SS 40	PG-S 40
		50mm	PG-50	PG-SS 50
				PG-S 50

THREE TYPES OF SHELL: (1) PG-P:plastic (2) PG-SS:stainless steel (3) PG-S:steel
THE CONNECTIONS HAVE TWO TYPES: (1)G 1/4" (2)M10x1
FOR 40MM GAUGE,THE SCALE IS 0-10 BAR OR 0-6 BAR

TWO TYPES OF CONNECTIONS: A:BACK CONNECTION B:BOTTOM CONNECTION FOR 40MM GAUGE, THE SCALE IS 0-6 BAR

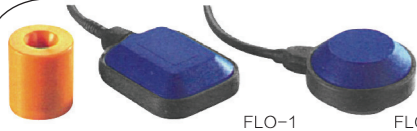
	Model	VOLTAGE	CURRENT	AMBIENT TEMPERATURE
	FLO-1	220V-240V	8A	0-80°C
	FLO-2	220V-240V	8A	0-80°C

	Model	VOLTAGE	FREQUENCY	CURRENT	CONNECTIONS	PROTECTION
	PS-01	220V-240V 110V-115V	50/60Hz	10A	1" × 1"	IP 65

	Model	VOLTAGE	FREQUENCY	CURRENT	CONNECTIONS	PROTECTION
	PS-01A	220V-240V 110V-115V	50/60Hz	10A	1" × 1"	IP 65

	Model	VOLTAGE	FREQUENCY	CURRENT	CONNECTIONS	PROTECTION
	PS-01B	220V-240V 110V-115V	50/60Hz	12A	1" × 1"	IP 65

	Model	VOLTAGE	FREQUENCY	CURRENT	CONNECTIONS	PROTECTION
	PS-01C	220V-240V 110V-115V	50/60Hz	12A	1" × 1"	IP 65

2.5SGm

2.5"Deep Well Pumps



Application Limits

- Max. ambient temperature 40°C ;
- Maximum permissible quantity of sand:100g/m³ ;
- Hydrogen sulfide content up to 1.5mg/L, chloride ion content up to 400mg/L;
- pH 6.5 to 8.5;
- Maximum: 70 m below the static water table.

Advantages & Features

- Edible oil filled motor, stable& reliable running with pressureregulating membrane;
- Single phase motor equipped with capacitor & current mode thermal protector, convenient for replacement;
- Installation in 2.5" or larger boreholes;
- Brass oil chamber.

Performance Data

Model	Power		Flow									Head Range (m)	Packing Dim(mm) Pump (L×W×H)	G.W. (kg)	Discharge (in)
	kW	HP	m³/h	0	0.3	0.6	0.9	1.2	1.5	1.8	2.1				
2.5SGm1.5/17	0.25	0.33	45	43	40	37	34	30	24	17	6	41~21	1300*80*185	8.8	G1
2.5SGm1.5/24	0.37	0.5	64	60	56	52	48	41	33	22	8	58~28	1500*80*185	10.5	
2.5SGm1.5/31	0.55	0.75	83	77	72	68	62	55	44	30	11	74~37	1800*80*185	12.2	
2.5SGm1/22	0.25	0.33	58	57	52	45	31	13	-	-	-	57~25	1300*80*185	8.9	
2.5SGm1/33	0.37	0.5	90	88	78	67	44	17	-	-	-	88~35	1600*80*185	10.8	
2.5SGm1/48	0.55	0.75	131	126	114	94	68	22	-	-	-	126~55	1900*80*185	13.2	

3SGm

3" Deep Well Pumps



Application Limits

- Max. ambient temperature < 40°C ;
- Sand content (in mass fraction) up to 0.01%;
- Hydrogen sulfide content up to 1.5mg/L, chloride ion content up to 400mg/L;
- pH 6.5 to 8.5;
- Maximum: 70 m below the static water table.

Advantages & Features

- Edible oil filled motor, stable & reliable running with pressure regulating membrane;
- Single phase motor equipped with start box which built in capacitor & current mode thermal protector, convenient for replacement;
- Pump sleeve with screw thread, single stage floating impellers;
- Installation in 3" or larger boreholes.

Performance Data

Model	Power		Flow												Head Range (m)	Packing Dim(mm) Pump (L×W×H)	G.W. (kg)	Discharge (In)
	kW	HP	m³/h	0	0.6	0.9	1.2	1.5	1.8	2.1	2.4	2.7	3	3.6				
			l/min	0	10	15	20	25	30	35	40	45	50	60				
3SGm1.8/7	0.18	0.25	30	29	29	27	25	23	20	16	11	-	-	29~11	915×90×185	6.5	G1	
3SGm1.8/10	0.25	0.33	43	42	41	39	36	33	28	23	16	-	-	42~16	1010×90×185	7.5		
3SGm1.8/14	0.37	0.5	60	59	57	54	51	46	40	32	23	-	-	59~23	1150×90×185	12.5		
3SGm1.8/20	0.55	0.75	86	84	82	78	73	66	57	46	32	-	-	84~32	1325×90×185	11		
3SGm1.8/27	0.75	1	115	113	110	105	98	88	76	62	44	-	-	113~44	1540×90×185	13		
3SGm1.8/33	1.1	1.5	142	139	136	130	120	109	93	77	53	-	-	139~53	1760×90×185	15.5		
3SGm2.5/5	0.18	0.25	21	21	20	20	19	18	17	16	14	12	7	20~10	920×90×185	6		
3SGm2.5/7	0.25	0.33	30	29	29	28	27	26	24	22	20	17	10	29~14	1000×90×185	7		
3SGm2.5/10	0.37	0.5	41	41	41	40	38	37	34	32	28	24	14	41~20	1100×90×185	8		
3SGm2.5/15	0.55	0.75	62	62	61	60	57	55	52	47	42	37	20	61~30	1300×90×185	10		
3SGm2.5/20	0.75	1	83	83	82	79	77	73	69	63	57	49	27	82~39	1470×90×185	11.5		
3SGm2.5/25	1.1	1.5	104	103	102	99	96	92	86	79	71	61	34	102~49	1710×90×185	14		

Model	Power		Flow												Head Range (m)	Packing Dim(mm) Pump (L×W×H)	G.W. (kg)	Discharge (In)
	kW	HP	m³/h	0	0.6	1.2	1.8	2.4	3	3.6	4.2	4.8	5.4					
			l/min	0	10	20	30	40	50	60	70	80	90					
3SGm4/4	0.18	0.25	17	17	16	15	15	14	13	11	9	5	5 ~ 16	920×90×185	6.0	G¼		
3SGm4/6	0.25	0.33	25	25	24	23	22	21	19	16	13	8	8 ~ 24	980×90×185	7.0			
3SGm4/9	0.37	0.5	37	37	36	35	33	32	28	24	19	12	12 ~ 36	1100×90×185	8.0			
3SGm4/12	0.55	0.75	49	49	48	47	45	42	37	32	25	15	15 ~ 48	1265×90×185	9.5			
3SGm4/16	0.75	1	66	66	65	62	59	56	50	42	34	21	21 ~ 65	1435×90×185	10.5			
3SGm4/20	0.92	1.25	82	82	81	78	74	70	62	53	42	25	25 ~ 81	1650×90×185	12.5			
3SGm4/24	1.1	1.5	99	99	97	93	89	84	75	63	51	31	31 ~ 97	1760×90×185	14.5			

3SPm

3"Deep Well Pumps



Application Limits

- Max. ambient temperature < 40°C ;
- Sand content (in mass fraction) up to 0.01%;
- Hydrogen sulfide content up to 1.5mg/L, chloride ion content up to 400mg/L;
- pH 6.5 to 8.5;
- Maximum: 70 m below the static water table

Advantages & Features

- Edible oil filled motor, stable& reliable running with pressure regulating membrane;
- Single phase motor equipped with start box which built in capacitor & current mode thermal protector, convenient for replacement;
- Pump sleeve with screw thread, single stage floating impellers;
- Installation in 3" or larger boreholes.

Performance Data

Model	Power		Flow												Head Range (m)	Packing Dim(mm) Pump (L×W×H)	G.W. (kg)	Discharge (In)
	Single-Phase	kW	HP	m³/h	0	0.6	0.9	1.2	1.5	1.8	2.1	2.4	2.7	3				
220V			l/min	0	10	15	20	25	30	35	40	45	50	60				
3SPm2.5/5	0.18	0.25	H(m)	20	20	19	19	18	18	17	15	13	12	6	19~10	920×90×185	7	G1
3SPm2.5/7	0.25	0.33		29	28	27	26	26	25	24	21	19	18	12	27~17	980×90×185	8	
3SPm2.5/10	0.37	0.5		41	40	39	39	38	37	35	33	30	27	18	39~24	1100×90×185	9.5	
3SPm2.5/15	0.55	0.75		62	60	58	58	56	54	51	47	44	40	25	58~35	1300×90×185	11.5	
3SPm2.5/20	0.75	1		83	81	76	76	74	73	70	64	59	53	34	76~49	1470×90×185	13	
3SPm2.5/25	1.1	1.5		106	103	101	99	95	93	89	82	77	64	48	101~57	1710×90×185	16	

Model	Power		Flow												Head Range (m)	Packing Dim(mm) Pump (L×W×H)	G.W. (kg)	Discharge (In)
	Single-Phase	kW	HP	m³/h	0	0.6	1.2	1.8	2.4	3	3.6	4.2	4.8	5.4				
220V			l/min	0	10	20	30	40	50	60	70	80	90					
3SPm4/4	0.18	0.25	H(m)	17	17	16	15	15	14	13	11	9	5	5 ~ 16	920×90×185	6.0	G¼	
3SPm4/6	0.25	0.33		25	25	24	23	22	21	19	16	13	8	8 ~ 24	980×90×185	7.0		
3SPm4/9	0.37	0.5		37	37	36	35	33	32	28	24	19	12	12 ~ 36	1100×90×185	8.0		
3SPm4/12	0.55	0.75		49	49	48	47	45	42	37	32	25	15	15 ~ 48	1265×90×185	9.5		
3SPm4/16	0.75	1		66	66	65	62	59	56	50	42	34	21	21 ~ 65	1435×90×185	10.5		
3SPm4/20	0.92	1.25		82	82	81	78	74	70	62	53	42	25	25 ~ 81	1650×90×185	12.5		
3SPm4/24	1.1	1.5	99	99	97	93	89	84	75	63	51	31	31 ~ 97	1760×90×185	14.5			

3SEm-T

3" Deep Well Pumps



Application Limits

- Max. ambient temperature < 40°C ;
- Sand content (in mass fraction) up to 0.01%;
- Hydrogen sulfide content up to 1.5mg/L, chloride ion content up to 400mg/L;
- pH 6.5 to 8.5;
- Maximum: 70 m below the static water table.

Advantages & Features

- Edible oil filled motor, stable & reliable running with pressure regulating membrane;
- Single phase motor with built in B Grade oil proofed capacitor & thermal mode protector;
- Available with pump casing with plug, single stage floating impellers;
- Installation in 3" or larger boreholes.

Performance Data

Model	Power		Flow									Head Range (m)	Packing Dim(mm) Pump (L×W×H)	G.W. (kg)	Discharge (In)	
	Single-Phase	kW	HP	m³/h	0	0.6	0.9	1.2	1.5	1.8	2.1					2.7
				220V	l/min	0	10	15	20	25	30					35
3SEm1.8/7T	0.18	0.25	H(m)	30	29	29	27	25	23	20	11	29~11	830×90×125	7.2	G1	
3SEm1.8/10T	0.25	0.33		43	42	41	39	36	33	28	16	42~16	910×90×125	8.1		
3SEm1.8/14T	0.37	0.5		60	59	57	54	51	46	40	23	59~23	1050×90×125	9.3		
3SEm1.8/20T	0.55	0.75		86	84	82	78	73	66	57	32	84~32	1230×90×125	11.0		
3SEm1.8/27T	0.75	1		115	113	110	105	98	88	76	44	113~44	1450×90×125	12.5		
3SEm1.8/33T	1.1	1.5		142	139	136	130	120	109	93	53	139~53	1660×90×125	15.3		

Model	Power		Flow												Head Range (m)	Packing Dim(mm) Pump (L×W×H)	G.W. (kg)	Discharge (In)	
	Single-Phase	kW	HP	m³/h	0	0.6	0.9	1.2	1.5	1.8	2.1	2.4	2.7	3					3.6
				220V	l/min	0	10	15	20	25	30	35	40	45					50
3SEm2.5/5T	0.18	0.25	H(m)	21	21	20	20	19	18	17	16	14	12	7	20~10	800×90×125	7.1	G1	
3SEm2.5/7T	0.25	0.33		30	29	29	28	27	26	24	22	20	17	10	29~14	870×90×125	7.9		
3SEm2.5/10T	0.37	0.5		41	41	41	40	38	37	34	32	28	24	14	41~20	980×90×125	8.9		
3SEm2.5/15T	0.55	0.75		62	62	61	60	57	55	52	47	42	37	20	61~30	1180×90×125	10.6		
3SEm2.5/20T	0.75	1		83	83	82	79	77	73	69	63	57	49	27	82~39	1330×90×125	11.7		
3SEm2.5/25T	1.1	1.5		104	103	102	99	96	92	86	79	71	61	34	102~49	1570×90×125	14.6		

3.5SEm-T

3.5" Deep Well Pumps



Application Limits

- Max. ambient temperature < 40°C ;
- Sand content (in mass fraction) up to 0.01%;
- hydrogen sulfide content up to 1.5mg/L, chloride ion content up to 400mg/L;
- pH 6.5 to 8.5;
- Maximum: 70 m below the static water table.

Advantages & Features

- Edible oil filled motor, stable & reliable running with pressure regulating membrane;
- Single phase motor with built in B Grade oil proofed capacitor & thermal mode protector;
- Available with cable with a motor plug, disassemble conveniently;
- Available with pump casing with plug, integrated stage floating impellers;
- Installation in 3.5" or larger boreholes;

Performance Data

Model	Power		Flow								Head Range (m)	Packing Dim(mm) Pump (L×W×H)	G.W. (kg)	Discharge (In)
	kW	HP	m³/h	0	0.6	1.2	1.8	2.4	3	3.6				
			l/min	0	10	20	30	40	50	60				
3.5SEm2/8T	0.37	0.5	H(m)	42	41	38	35	31	24	15	41~22	890×105×185	13	G½
3.5SEm2/10T	0.55	0.75		53	51	49	46	38	31	19	51~29	960×105×185	14	
3.5SEm2/12T	0.75	1		63	61	57	52	44	34	20	61~32	1020×105×185	15	
3.5SEm2/14T	0.9	1.2		74	73	70	65	54	45	28	73~42	1100×105×185	17	
3.5SEm2/18T	1.1	1.5		95	92	87	78	68	55	34	92~51	1210×105×185	18	
3.5SEm2/26T	1.5	2		137	132	124	112	95	74	47	132~69	1460×105×185	22	
3.5SEm2/32T	1.8	2.4		169	164	158	146	127	101	70	164~89	M:680x105x220 B:1180x105x125	M:15.5 B:8.5	

Model	Power		Flow												Head Range (m)	Packing Dim(mm) Pump (L×W×H)	G.W. (kg)	Discharge (In)
	kW	HP	m³/h	0	1.2	1.8	2.4	3	3.6	4.2	4.8	5.4	6	7.2				
			l/min	0	20	30	40	50	60	70	80	90	100	120				
3.5SEm3/8T	0.37	0.5	H(m)	37	33	32	30	28	25	23	20	17	13	3	33~17	1000×105×185	13.5	G½
3.5SEm3/10T	0.55	0.75		46	42	40	37	35	32	28	24	20	16	4	42~20	1100×105×185	15	
3.5SEm3/12T	0.75	1		55	50	48	45	41	38	34	29	23	17	5	50~23	1190×105×185	16	
3.5SEm3/14T	0.9	1.2		64	59	56	52	48	44	39	34	30	25	6	59~30	1295×105×185	18	
3.5SEm3/18T	1.1	1.5		83	75	72	67	62	57	52	44	39	29	9	75~39	1465×105×185	19.5	
3.5SEm3/25T	1.5	2		115	105	100	93	86	79	67	51	45	36	11	105~45	M:650x105x220 B:1330x105x125	M:13.5 B:8.5	
3.5SEm3/28T	1.8	2.4		128	122	119	112	104	95	84	73	63	52	11	122~65	M:680x105x220 B:1460x105x125	M:15.5 B:9.5	

4SG(m)

4"Deep Well Pumps

Application Limits

- Max. ambient temperature < 40°C ;
- Sand content (in mass fraction) up to 0.01%;
- hydrogen sulfide content up to 1.5mg/L, chloride ion content up to 400mg/L;
- pH 6.5 to 8.5;
- Maximum: 70 m below the static water table.

Advantages & Features

- Edible oil filled motor, stable& reliable running with pressure regulating membrane;
- Single phase motor equipped with start box which built in capacitor & current mode thermal protector, convenient for replacement;
- Available with cable with a motor plug, disassemble conveniently;
- Pump sleeve with screw thread, single stage floating impellers, except 16 m3/hrs series which with integrated stage floating impellers;
- Installation in 4" or larger boreholes;



Performance Data

Model	Power		Flow												Head Range (m)	Packing Dim(mm) Pump (L×W×H)		G.W. (kg)		Discharge (In)	
	Single-Phase	Three-Phase	kW	HP	m³/h	0	0.6	1.2	1.5	1.8	2.1	2.4	2.7	3		3.6	Single-Phase	Three-Phase	Single-Phase		Three-Phase
					l/min	0	10	20	25	30	35	40	45	50		60					
4SGm2/8	-	-	0.37	0.5	58	55	52	50	46	43	38	34	27	15	55~22	1020×110×185	-	13.7	-	G1¼ / (G1½ / G2)	
4SGm2/11	-	-	0.55	0.75	80	79	74	71	67	62	56	49	41	23	77~34	1100×110×185	-	15.1	-		
4SGm2/14	4SG2/14	0.75	1	103	99	93	89	84	82	70	62	51	30	99~43	1220×110×185	1075×125×125	17.0	15.3			
4SGm2/16	4SG2/16	0.75	1	117	113	106	102	96	94	80	71	58	35	113~49	1280×110×185	1130×125×125	17.5	15.8			
4SGm2/19	4SG2/19	1.1	1.5	140	135	127	122	115	107	98	86	71	42	135~60	1415×110×185	1310×125×125	20.0	18.4			
4SGm2/22	4SG2/22	1.1	1.5	162	156	147	141	133	124	113	100	82	50	156~69	1500×110×185	1310×125×125	20.7	19.1			
4SGm2/25	4SG2/25	1.5	2	184	178	169	162	152	142	128	114	96	58	178~81	M:770×125×225 B:980×125×125	M:645×125×125 B:980×125×125	M:17 B:7.8	M:14.0 B:7.8			
4SGm2/28	4SG2/28	1.5	2	206	199	189	181	170	159	143	128	108	62	199~91	M:770×125×225 B:1075×125×125	M:645×125×125 B:1075×125×125	M:17 B:8.4	M:14.0 B:8.4			
4SGm2/33	4SG2/33	2.2	3	246	238	226	216	204	191	174	153	130	80	238~110	M:870×125×225 B:1180×125×125	M:690×125×125 B:1180×125×125	M:22.5 B:9.3	M:16.5 B:9.3			
4SGm2/38	4SG2/38	2.2	3	283	274	260	249	235	220	200	176	150	91	274~127	M:870×125×225 B:1310×125×125	M:690×125×125 B:1310×125×125	M:22.5 B:10.2	M:16.5 B:10.2			
-	4SG2/44	3	4	321	311	295	284	269	250	225	198	165	96	311~137	-	M:780×125×125 B:1500×125×125	-	-	M:20.5 B:13		
-	4SG2/50	3	4	364	353	335	323	306	284	256	225	188	109	353~156	-	M:780×125×125 B:1680×125×125	-	-	M:20.5 B:14.1		
-	4SG2/56	4	5.5	411	396	376	361	342	318	289	252	206	122	396~175	-	M:825×125×125 B:1855×125×125	-	-	M:23.5 B:15		
-	4SG2/62	4	5.5	454	438	416	400	379	352	320	279	228	135	438~190	-	M:825×125×125 B:1980×125×125	-	-	M:23.5 B:16		

4SE(m)-T

4"Deep Well Pumps



Application Limits

- Max. ambient temperature < 40°C ;
- Sand content (in mass fraction) up to 0.01%;
- hydrogen sulfide content up to 1.5mg/L, chloride ion content up to 400mg/L;
- pH 6.5 to 8.5;
- Maximum: 70 m below the static water table.

Advantages & Features

- Edible oil filled motor, stable& reliable running with pressure regulating membrane;
- Single phase motor with built in B Grade oil proofed capacitor & thermal mode protector;
- Available with cable with a motor plug, disassemble conveniently;
- Available with pump casing with plug, 2~8 m3/hrs series with single stage floating impellers, 10~16m3/hrs series with integrated stage floating impellers;
- Installation in 4" or larger boreholes;

Performance Data

Model	Power	Flow											Head Range (m)	Packing Dim(mm) Pump (L x W x H)		G.W. (kg)		Discharge (in)			
		Single-Phase	Three-Phase	kW	HP	m³/h	0	0.6	0.9	1.2	1.5	1.8		2.1	2.4	3	3.6		Single-Phase	Three-Phase	Single-Phase
					l/min	0	10	15	20	25	30	35	40	50	60						
4SEm2/8T	-	0.37	0.5		58	55	54	52	50	46	43	38	27	15	55~22	890 × 125 × 125	-	15.0	-	G1½/ (G2)	
4SEm2/11T	-	0.55	0.75		80	79	77	74	71	67	62	56	41	23	77~34	980 × 125 × 125	-	16.4	-		
4SEm2/14T	4SE2/14T	0.75	1		103	99	97	93	89	84	82	70	51	30	99~43	1100 × 125 × 125	1100 × 125 × 125	18.3	16.6		
4SEm2/16T	4SE2/16T	0.75	1		117	113	111	106	102	96	94	80	58	35	113~49	1130 × 125 × 125	1130 × 125 × 125	18.8	17.1		
4SEm2/19T	4SE2/19T	1.1	1.5		140	135	133	127	122	115	107	98	71	42	135~60	1310 × 125 × 125	1310 × 125 × 125	21.3	19.7		
4SEm2/22T	4SE2/22T	1.1	1.5		162	156	154	147	141	133	124	113	82	50	156~69	1360 × 125 × 125	1360 × 125 × 125	22.0	20.4		
4SEm2/25T	4SE2/25T	1.5	2		184	178	174	169	162	152	142	128	96	58	178~81	M:645 × 125 × 125 B:1020 × 125 × 125	M:640 × 125 × 125 B:1020 × 125 × 125	M:17 B:9.4	M:14 B:9.4		
4SEm2/28T	4SE2/28T	1.5	2	H(m)	206	199	195	189	181	170	159	143	108	62	199~91	M:645 × 125 × 125 B:1075 × 125 × 125	M:640 × 125 × 125 B:1075 × 125 × 125	M:17 B:10	M:14 B:10		
4SEm2/33T	4SE2/33T	2.2	3		246	238	233	226	216	204	191	174	130	80	238~110	M:690 × 125 × 125 B:1210 × 125 × 125	M:690 × 125 × 125 B:1210 × 125 × 125	M:22.5 B:10.9	M:16.5 B:10.9		
4SEm2/38T	4SE2/38T	2.2	3		283	274	268	260	249	235	220	200	150	91	274~127	M:690 × 125 × 125 B:1360 × 125 × 125	M:690 × 125 × 125 B:1360 × 125 × 125	M:22.5 B:11.8	M:16.5 B:11.8		
-	4SE2/44T	3	4		321	311	304	295	284	269	250	225	165	96	311~137	-	M:780 × 125 × 125 B:1520 × 125 × 125	-	M:20.5 B:14.6		
-	4SE2/50T	3	4		364	353	345	335	323	306	284	256	188	109	353~156	-	M:780 × 125 × 125 B:1680 × 125 × 125	-	M:20.5 B:15.7		
-	4SE2/56T	4	5.5		411	396	386	376	361	342	318	289	206	122	396~175	-	M:825 × 125 × 125 B:1855 × 125 × 125	-	M:23.5 B:16.6		
-	4SE2/62T	4	5.5		454	438	427	416	400	379	352	320	228	135	438~190	-	M:825 × 125 × 125 B:2015 × 125 × 125	-	M:23.5 B:17.6		

Model	Power	Flow								Head Range (m)	Packing Dim(mm) Pump (L x W x H)		G.W. (kg)		Discharge (in)					
		Single-Phase	Three-Phase	kW	HP	m³/h	0	1.2	1.8		2.4	3	3.6	4.8		Single-Phase	Three-Phase	Single-Phase	Three-Phase	
					l/min	0	20	30	40	50	60	80								
4SEm3/7T	-	0.37	0.5		49	47	44	40	35	28	12	47~25	890 × 125 × 125	-	14.8	-	G1½/ (G2)			
4SEm3/9T	-	0.55	0.75		65	63	60	55	48	40	19	63~35	935 × 125 × 125	-	16.0	-				
4SEm3/11T	4SE3/11T	0.75	1		81	78	75	68	60	49	24	78~43	1020 × 125 × 125	1020 × 125 × 125	17.6	15.9				
4SEm3/13T	4SE3/13T	0.75	1		96	92	89	80	71	58	28	92~51	1075 × 125 × 125	1075 × 125 × 125	18.0	16.3				
4SEm3/15T	4SE3/15T	1.1	1.5		110	106	102	96	84	68	28	106~59	1180 × 125 × 125	1180 × 125 × 125	20.4	18.8				
4SEm3/17T	4SE3/17T	1.1	1.5		125	120	116	109	95	77	32	120~67	1255 × 125 × 125	1255 × 125 × 125	20.8	19.2				
4SEm3/19T	4SE3/19T	1.5	2		140	136	130	120	106	87	43	136~77	M:645 × 125 × 225 B:890 × 125 × 125	M:640 × 125 × 125 B:890 × 125 × 125	M:17 B:8.7	M:15 B:8.7				
4SEm3/21T	4SE3/21T	1.5	2	H(m)	155	150	144	133	117	96	48	150~85	M:645 × 125 × 225 B:935 × 125 × 125	M:640 × 125 × 125 B:935 × 125 × 125	M:17 B:9.1	M:15 B:9.1				
4SEm3/26T	4SE3/26T	2.2	3		195	190	182	168	150	124	65	190~111	M:690 × 125 × 225 B:1075 × 125 × 125	M:690 × 125 × 125 B:1075 × 125 × 125	M:22.5 B:10.2	M:16.5 B:10.2				
4SEm3/30T	4SE3/30T	2.2	3		225	219	210	194	173	143	75	219~127	M:690 × 125 × 225 B:1180 × 125 × 125	M:690 × 125 × 125 B:1180 × 125 × 125	M:22.5 B:11.1	M:16.5 B:11.1				
-	4SE3/35T	3	4		260	253	243	224	198	163	78	253~144	-	M:780 × 125 × 125 B:1360 × 125 × 125	-	M:20.5 B:12.4				
-	4SE3/40T	3	4		297	289	278	256	226	186	89	289~165	-	M:780 × 125 × 125 B:1460 × 125 × 125	-	M:20.5 B:13.5				
-	4SE3/45T	4	5.5		332	324	310	288	256	208	107	324~185	-	M:825 × 125 × 125 B:1580 × 125 × 125	-	M:23.5 B:15.1				
-	4SE3/50T	4	5.5		369	360	344	320	284	231	114	360~206	-	M:825 × 125 × 125 B:1735 × 125 × 125	-	M:23.5 B:16.2				
-	4SE3/55T	5.5	7.5		400	393	380	355	323	250	115	393~219	-	M:920 × 125 × 125 B:1880 × 125 × 125	-	M:27.5 B:17.3				
-	4SE3/60T	5.5	7.5		436	429	415	387	352	273	125	429~241	-	M:920 × 125 × 125 B:2015 × 125 × 125	-	M:27.5 B:18.4				

Model		Power		Flow							Head Range (m)	Packing Dim(mm) Pump (L×W×H)		G.W. (kg)		Discharge (In)
Single-Phase	Three-Phase	kW	HP	m³/h	0	3.6	5.4	9.0	10.8	12.6		16.2	Single-Phase	Three-Phase	Single-Phase	
				l/min	0	60	90	150	180	210	270					
4SEm12/3T	4SE12/3T	0.75	1	19	17	17	14	12	10	2	18~7	935×110×185	935×110×185	17.0	15.3	G2
4SEm12/4T	4SE12/4T	0.75	1	25	23	22	19	16	13	3	23~9	980×110×185	980×110×185	17.4	15.7	
4SEm12/5T	4SE12/5T	1.1	1.5	32	30	29	24	21	18	5	29~13	1075×110×185	1075×110×185	19.8	18.2	
4SEm12/6T	4SE12/6T	1.1	1.5	38	36	35	29	25	21	6	35~16	1100×110×185	1100×110×185	20.2	18.6	
4SEm12/7T	4SE12/7T	1.5	2	47	45	41	35	30	26	8	43~18	M:645×125×125 B:730×125×125	M:640×125×125 B:730×125×125	M:17 B:7.4	M:14 B:7.4	
4SEm12/8T	4SE12/8T	1.5	2	53	51	47	40	34	30	9	49~21	M:645×125×125 B:730×125×125	M:640×125×125 B:730×125×125	M:17 B:7.8	M:14 B:7.8	
4SEm12/10T	4SE12/10T	2.2	3	65	63	58	48	43	37	12	61~29	M:690×125×125 B:890×125×125	M:690×125×125 B:890×125×125	M:22.5 B:8.9	M:16.5 B:8.9	
4SEm12/12T	4SE12/12T	2.2	3	78	76	70	58	51	44	14	73~35	M:690×125×125 B:980×125×125	M:690×125×125 B:980×125×125	M:22.5 B:9.7	M:16.5 B:9.7	
-	4SE12/14T	3	4	91	86	79	66	58	50	17	83~39	-	M:780×125×125 B:1100×125×125	-	M:20.5 B:11	
-	4SE12/16T	3	4	103	98	90	75	66	57	19	95~45	-	M:780×125×125 B:1180×125×125	-	M:20.5 B:11.8	
-	4SE12/18T	4	5.5	115	112	104	86	77	69	23	107~50	-	M:825×125×125 B:1360×125×125	-	M:23.5 B:12.9	
-	4SE12/20T	4	5.5	127	124	115	96	85	77	25	119~56	-	M:825×125×125 B:1460×125×125	-	M:23.5 B:13.7	
-	4SE12/23T	5.5	7.5	146	140	130	109	96	82	29	134~61	-	M:920×125×125 B:1580×125×125	-	M:27.5 B:15.9	
-	4SE12/26T	5.5	7.5	165	158	147	123	109	93	33	152~69	-	M:920×125×125 B:1735×125×125	-	M:27.5 B:17.3	
-	4SE12/29T	7.5	10	184	175	161	136	122	103	39	171~80	-	M:1040×125×125 B:1980×125×125	-	M:33.5 B:18.6	
-	4SE12/32T	7.5	10	202	193	178	150	135	114	43	189~88	-	M:1040×125×125 B:2150×125×125	-	M:33.5 B:20	

Model		Power		Flow						Head Range (m)	Packing Dim(mm) Pump (L×W×H)		G.W. (kg)		Discharge (In)	
Single-Phase	Three-Phase	kW	HP	m³/h	0	9	12	15	18		21	Single-Phase	Three-Phase	Single-Phase		Three-Phase
				l/min	0	150	200	250	300	350						
4SEm16/3T	4SE16/3T	1.1	1.5	19	14	11	9	5	-	-	17~2	1075×125×125	1020×125×125	19.3	17.7	G2
4SEm16/4T	4SE16/4T	1.1	1.5	25	19	15	12	7	-	-	23~3	1130×125×125	1100×125×125	19.9	18	
4SEm16/5T	4SE16/5T	1.5	2	31	24	21	17	11	2	2	28~7	M:645×125×225 B:730×125×125	M:645×125×125 B:730×125×125	M:17 B:7.3	M:15 B:7.3	
4SEm16/6T	4SE16/6T	1.5	2	37	29	25	20	13	3	3	34~8	M:645×125×225 B:810×125×125	M:645×125×125 B:810×125×125	M:17 B:7.9	M:15 B:7.9	
4SEm16/8T	4SE16/8T	2.2	3	47	37	32	26	17	4	4	45~12	M:690×125×225 B:955×125×125	M:690×125×125 B:955×125×125	M:22.5 B:8.8	M:16.5 B:8.8	
4SEm16/9T	4SE16/9T	2.2	3	53	42	36	29	19	5	5	49~13	M:690×125×225 B:1020×125×125	M:690×125×125 B:1020×125×125	M:22.5 B:9.4	M:16.5 B:9.4	
-	4SE16/11T	3	4	66	55	47	40	27	7	7	62~19	-	M:780×125×125 B:1180×125×125	-	M:20.5 B:10.8	
-	4SE16/12T	3	4	72	60	51	44	29	8	8	68~19	-	M:780×125×125 B:1255×125×125	-	M:20.5 B:11.4	
-	4SE16/14T	4	5.5	84	70	60	51	34	9	9	79~22	-	M:825×125×125 B:1415×125×125	-	M:23.5 B:12.3	
-	4SE16/16T	4	5.5	96	80	69	58	39	10	10	91~25	-	M:825×125×125 B:1580×125×125	-	M:23.5 B:13.5	
-	4SE16/18T	5.5	7.5	108	90	77	65	44	11	11	102~29	-	M:920×125×125 B:1735×125×125	-	M:27.5 B:14.9	
-	4SE16/20T	5.5	7.5	120	100	86	72	49	12	12	114~32	-	M:920×125×125 B:1855×125×125	-	M:27.5 B:16.1	
-	4SE16/22T	7.5	10	133	109	94	80	54	14	14	125~35	-	M:1015×125×125 B:2015×125×125	-	M:33.5 B:16.9	
-	4SE16/24T	7.5	10	145	119	103	87	59	15	15	136~38	-	M:1015×125×125 B:2200×125×125	-	M:33.5 B:18.1	

4SS(m)

4"Deep Well Pumps

Application Limits

- Max. ambient temperature < 40°C ;
- Sand content (in mass fraction) up to 0.01%;
- Hydrogen sulfide content up to 1.5mg/L, chloride ion content up to 400mg/L;
- pH 6.5 to 8.5;
- Maximum: 70 m below the static water table.

Advantages & Features

- Edible oil filled motor, stable& reliable running with pressure regulating membrane;
- Single phase motor equipped with start box which built in capacitor & current mode thermal protector, convenient for replacement;
- Available with stainless steel pump head, effective against the corrosion and abrasive wear;
- Installation in 4" or larger boreholes.



Performance Data

Model		Power		Flow					Head Range (m)	Packing Dim(mm) Pump (L×W×H)		G.W. (kg)		Discharge (In)	
Single-Phase	Three-Phase	kW	HP	m³/h	0	1.2	1.8	2.4		3	Single-Phase	Three-Phase	Single-Phase		Three-Phase
				l/min	0	20	30	40	50						
4SSm2/9	-	0.37	0.5	54	46	39	30	18	18	50~26	980*110*185	-	13.9	-	G1¼ / (G1½ / G2)
4SSm2/13	-	0.55	0.75	78	66	56	44	26	26	72~38	1075*110*185	-	15.5	-	
4SSm2/18	4SS2/18	0.75	1	108	91	78	61	36	36	100~53	1220*110*185	1075*110*185	17.8	16.1	
4SSm2/23	4SS2/23	1.1	1.5	138	117	99	78	46	46	127~68	1360*110*185	1220*110*185	20.8	19.2	
4SSm2/28	4SS2/28	1.5	2	168	142	121	95	56	56	155~83	M:770*125*225 B:850*125*125	M:645*125*125 B:850*125*125	M:17 B:10.4	M:14 B:10.4	
4SSm2/40	4SS2/40	2.2	3	240	203	172	135	80	80	222~117	M:870*125*225 B:1100*125*125	M:690*125*125 B:1100*125*125	M:22.5 B:12.9	M:16.5 B:12.9	
-	4SS2/55	3	4	330	279	237	186	110	110	305~163	-	M:780*125*125 B:1415*125*125	-	M:20.5 B:16.1	

Performance Data

Model		Power		Flow							Head Range (m)	Packing Dim(mm) Pump (L x W x H)		G.W. (kg)		Discharge (In)
Single-Phase	Three-Phase	kW	HP	m³/h	0	1.2	1.8	2.4	3	3.6		4.2	Single-Phase	Three-Phase	Single-Phase	
4SSm3/6	-	0.37	0.5	37	33	31	29	26	21	13	34~17	890x110x185	-	13.3	-	G1½ / (G1½ / G2)
4SSm3/9	-	0.55	0.75	55	50	47	44	39	31	19	51~25	1020x110x185	-	14.7	-	
4SSm3/12	4SS3/12	0.75	1	73	67	63	58	51	41	25	68~33	1075x110x185	935x110x185	16.5	14.8	
4SSm3/18	4SS3/18	1.1	1.5	109	100	94	87	77	62	38	102~51	1220x110x185	1100x110x185	19.8	18.2	
4SSm3/22	4SS3/22	1.5	2	134	122	115	107	94	76	47	125~62	M:770x125x225 B:730x125x125	M:645x125x125 B:730x125x125	M:17 B:9.1	M:14 B:9.1	
4SSm3/32	4SS3/32	2.2	3	194	178	167	155	137	110	68	182~90	M:870x125x225 B:935x125x125	M:690x125x125 B:935x125x125	M:22.5 B:11.2	M:16.5 B:11.2	
-	4SS3/40	3	4	243	222	209	194	172	138	85	227~113	-	M:780x125x125 B:1100x125x125	-	M:20.5 B:12.9	
-	4SS3/52	4	5.5	316	289	272	252	223	179	110	296~147	-	M:825x125x125 B:1360x125x125	-	M:23.5 B:15.4	

Model		Power		Flow											Head Range (m)	Packing Dim(mm) Pump (L x W x H)		G.W. (kg)		Discharge (In)
Single-Phase	Three-Phase	kW	HP	m³/h	0	1.2	1.8	3	4.2	4.8	5.4	6	6.6	Single-Phase		Three-Phase	Single-Phase	Three-Phase		
4SSm5/4	-	0.37	0.5	25	23	22	20	18	17	15	12	9	23~9	890x110x185	-	12.7	-	G1½ / (G2)		
4SSm5/6	-	0.55	0.75	37	35	33	31	28	25	22	18	13	34~13	935x110x185	-	14	-			
4SSm5/8	4SS5/8	0.75	1	50	46	44	41	37	34	29	23	17	45~17	1020x110x185	890x110x185	15.7	14			
4SSm5/12	4SS5/12	1.1	1.5	75	69	67	62	55	50	44	35	26	68~26	1180x110x185	1020x110x185	18.7	17.1			
4SSm5/17	4SS5/17	1.5	2	106	98	94	87	78	71	62	50	36	96~36	M:770x125x225 B:675x125x125	M:645x125x125 B:675x125x125	M:17 B:8.1	M:14 B:8.1			
4SSm5/21	4SS5/21	2.2	3	131	121	116	108	96	88	76	61	44	119~44	M:870x125x225 B:770x125x125	M:690x125x125 B:770x125x125	M:22.5 B:9.1	M:16.5 B:9.1			
-	4SS5/32	3	4	200	184	178	165	147	134	116	94	68	181~68	-	M:780x125x125 B:1020x125x125	-	M:20.5 B:11.7			
-	4SS5/40	4	5.5	249	230	221	205	183	167	145	117	86	226~86	-	M:825x125x125 B:1210x125x125	-	M:23.5 B:13.7			
-	4SS5/52	5.5	7.5	325	299	289	267	239	218	189	152	111	294~111	-	M:920x125x125 B:1500x125x125	-	M:27.5 B:16.5			

Model		Power		Flow										Head Range (m)	Packing Dim(mm) Pump (L x W x H)		G.W. (kg)		Discharge (In)
Single-Phase	Three-Phase	kW	HP	m³/h	0	2.4	3.6	4.8	6	7.2	8.4	10.8	Single-Phase		Three-Phase	Single-Phase	Three-Phase		
4SSm8/5	4SS8/5	0.75	1	29	27	25	24	22	21	19	10	27~10	1075*110*185	935*110*185	16.7	15	G2		
4SSm8/7	4SS8/7	1.1	1.5	41	37	35	33	31	29	26	15	37~15	1220*110*185	1075*110*185	19.5	17.9			
4SSm8/10	4SS8/10	1.5	2	59	53	50	47	45	41	37	21	53~21	M:770*125*225 B:730*125*125	M:645*125*125 B:730*125*125	M:17 B:9.8	M:14 B:9.8			
4SSm8/12	4SS8/12	2.2	3	70	64	60	57	54	50	44	25	64~25	M:870*125*225 B:850*125*125	M:690*125*125 B:850*125*125	M:22.5 B:10.6	M:16.5 B:10.6			
-	4SS8/18	3	4	105	96	91	85	80	75	67	38	96~38	-	M:780*125*125 B:1075*125*125	-	M:20.5 B:13.2			
-	4SS8/24	4	5.5	140	128	121	113	108	100	89	50	128~50	-	M:825*125*125 B:1360*125*125	-	M:23.5 B:15.7			
-	4SS8/32	5.5	7.5	187	170	161	157	143	133	118	67	170~67	-	M:920*125*125 B:1680*125*125	-	M:27.5 B:19.0			

6SE-T

6"Deep Well Pumps



Application Limits

- Max. ambient temperature < 40°C ;
- Sand content (in mass fraction) up to 0.01%;
- hydrogen sulfide content up to 1.5mg/L, chloride ion content up to 400mg/L;
- pH 6.5 to 8.5;
- Maximum: 70 m below the static water table.

Advantages & Features

- Edible oil filled motor, stable& reliable running with pressure regulating membrane;
- Available with pump casing with plug, integrated stage floating impellers;
- Installation in 6" or larger boreholes.

Performance Data

Model	Power		Flow															Head Range (m)	Packing Dim(mm) Pump (L x W x H)	G.W. (kg)	Discharge (In)
	Three-Phase	380V	kW	HP	m³/h	0	2	4	6	8	10	12	14	16	18						
6SE10/10T	5.5	7.5	7.5	140	133	129	123	115	100	87	69	48	25	129~53	M:940x150x150 B:910x150x150	M:42.7 B:21.1	G3				
6SE10/14T	7.5	10	10	196	186	181	172	160	140	122	97	67	34	181~77	M:1000x150x150 B:1070x150x150	M:47.8 B:24.7					
6SE10/16T	9.2	12.5	12.5	224	213	206	197	183	160	139	110	77	39	210~97	M:1060x150x150 B:1210x150x150	M:53 B:27.1					
6SE10/20T	11	15	15	280	266	258	246	229	200	174	138	96	49	260~119	M:1130x150x150 B:1370x150x150	M:61.2 B:30.2					
6SE10/22T	13	17.5	17.5	308	293	284	197	252	220	202	169	127	54	290~137	M:1190x150x150 B:1450x150x150	M:67.3 B:33					
6SE10/26T	15	20	20	364	346	335	320	298	260	239	200	150	64	338~161	M:1230x150x150 B:1750x150x150	M:70.4 B:40					

Performance Data

Model	Power		Flow											Head Range (m)	Packing Dim(mm) Pump (L × W × H)	G.W. (kg)	Discharge (In)	
	Three-Phase	kW	HP	m³/h	0	3	6	9	12	15	18	21	24					27
				380V	l/min	0	50	100	150	200	250	300	350					400
6SE18/6T	5.5	7.5	H(m)	85	82	79	75	68	60	51	41	29	16	80~32	M:940x150x150 B:800x150x150	M:42.7 B:18.7	G3	
6SE18/9T	7.5	10		128	124	119	112	102	90	82	62	43	24	120~47	M:1000x150x150 B:950x150x150	M:47.8 B:22		
6SE18/11T	9.2	12.5		156	151	145	137	125	110	100	76	53	29	146~58	M:1060x150x150 B:1040x150x150	M:53 B:23.6		
6SE18/13T	11	15		186	179	179	169	149	137	118	90	66	34	176~71	M:1130x150x150 B:1130x150x150	M:61.2 B:25.3		
6SE18/15T	13	17.5		213	205	198	188	170	150	135	103	73	37	199~79	M:1190x150x150 B:1230x150x150	M:67.3 B:27.5		
6SE18/18T	15	20		257	247	240	233	206	189	163	125	91	39	243~99	M:1230x150x150 B:1370x150x150	M:70.4 B:30.8		

Model	Power		Flow											Head Range (m)	Packing Dim(mm) Pump (L × W × H)	G.W. (kg)	Discharge (In)
	Three-Phase	kW	HP	m³/h	0	5	10	15	20	25	30	35	40				
				380V	l/min	0	83	167	250	333	417	500	583				
6SE30/5T	5.5	7.5	H(m)	72	68	64	59	53	45	35	23	10	65~29	M:940x150x150 B:800x150x150	M:42.7 B:18.2	G3	
6SE30/7T	7.5	10		100	94	88	82	73	63	49	32	14	91~41	M:1000x150x150 B:910x150x150	M:47.8 B:20		
6SE30/9T	9.2	12.5		129	121	113	105	95	80	63	42	19	117~52	M:1060x150x150 B:1020x150x150	M:53 B:22.6		
6SE30/10T	11	15		143	134	125	117	105	89	69	46	21	130~62	M:1130x150x150 B:1070x150x150	M:61.2 B:23.6		
6SE30/11T	13	17.5		157	147	139	129	116	98	76	51	23	145~73	M:1190x150x150 B:1130x150x150	M:67.3 B:24.6		
6SE30/13T	15	20		186	174	164	153	137	116	90	60	27	175~85	M:1230x150x150 B:1230x150x150	M:70.4 B:26.6		

Model	Power		Flow											Head Range (m)	Packing Dim(mm) Pump (L × W × H)	G.W. (kg)	Discharge (In)		
	Three-Phase	kW	HP	m³/h	0	6	12	18	24	30	36	42	48					54	60
				380V	l/min	0	100	200	300	400	500	600	700					800	900
6SE45/5T	7.5	10	H(m)	76	71	66	61	56	51	46	41	35	27	18	65~20	M:1000x150x150 B:860x150x150	M:47.8 B:19.8	G3	
6SE45/6T	9.2	12.5		92	85	79	73	68	62	55	49	42	33	22	78~25	M:1060x150x150 B:930x150x150	M:53 B:20.9		
6SE45/7T	11	15		107	99	92	82	79	72	64	57	48	38	26	90~29	M:1130x150x150 B:1000x150x150	M:61.2 B:22.6		
6SE45/8T	13	17.5		122	113	105	98	90	82	73	65	55	44	29	103~33	M:1190x150x150 B:1070x150x150	M:67.3 B:24.2		
6SE45/9T	15	20		137	127	118	110	101	92	82	73	62	49	33	116~37	M:1230x150x150 B:1190x150x150	M:70.4 B:25.4		

6SS

6"Deep Well Pumps

Application Limits

- Max. ambient temperature < 40°C ;
- Sand content (in mass fraction) up to 0.01%;
- Hydrogen sulfide content up to 1.5mg/L, chloride ion content up to 400mg/L;
- pH 6.5 to 8.5;
- Maximum: 70 m below the static water table.

Advantages & Features

- Available with stainless steel pump head, effective against the corrosion and abrasive wear;
- Edible oil filled motor, stable & reliable running with pressure regulating membrane;
- Available with controller box, bring about general protection;
- Installation in 6" or larger boreholes.

Performance Data

Model	Power		Flow											Head Range (m)	Packing Dim(mm) Pump (L × W × H)	G.W. (kg)	Discharge (In)	
	Three-Phase	kW	HP	m³/h	0	3	6	9	12	15	18	21	24					27
				380V	l/min	0	50	100	150	200	250	300	350					400
6SS17/9	5.5	7.5	H(m)	85	82	81	79	74	67	57	45	30	13	81~38	M:940x150x150 B:950x150x150	M:42.7 B:17.2	G3	
6SS17/12	7.5	10		111	109	108	105	98	89	76	60	40	17	108~50	M:1000x150x150 B:1130x150x150	M:47.8 B:21.4		
6SS17/15	9.2	12.5		141	136	135	131	123	111	95	75	50	21	135~63	M:1060x150x150 B:1310x150x150	M:53 B:25.6		
6SS17/18	11	15		170	164	162	158	147	134	114	90	60	26	162~76	M:1130x150x150 B:1490x150x150	M:61.2 B:29.9		
6SS17/21	13	17.5		198	191	189	184	171	156	133	105	70	30	189~88	M:1190x150x150 B:1670x150x150	M:67.3 B:34.1		
6SS17/24	15	20		226	218	216	210	196	178	152	120	80	34	216~101	M:1230x150x150 B:1850x150x150	M:70.4 B:38.3		



Submersible Pump for Deep Well

Performance Data

Model	Power		Flow																Head Range (m)	Packing Dim(mm) Pump (L×W×H)	G.W. (kg)	Discharge (In)	
	Three-Phase	kW	HP	m³/h	0	3	6	9	12	15	18	21	24	27	30	33	36	39					42
				l/min	0	50	100	150	200	250	300	350	400	450	500	550	600	650					700
6SS30/5	5.5	7.5		56	55	54	53	51	49	46	43	41	37	32	27	22	16	9	53~16	M:940x150x150 B:840x150x150	M:42.7 B:14.3	G3	
6SS30/7	7.5	10		78	77	76	74	72	68	64	60	57	45	38	31	22	12	74~22	M:1000x150x150 B:1070x150x150	M:47.8 B:18.3			
6SS30/10	9.2	12.5	H(m)	111	110	109	106	103	97	91	86	83	64	60	54	46	31	17	106~31	M:1060x150x150 B:1370x150x150	M:53 B:24.3		
6SS30/12	11	15		134	132	130	127	123	117	110	103	98	77	65	65	53	38	21	127~38	M:1130x150x150 B:1550x150x150	M:61.2 B:28.2		
6SS30/14	13	17.5		156	154	152	148	144	136	128	120	114	90	76	76	62	44	24	148~44	M:1190x150x150 B:1750x150x150	M:67.3 B:32.2		
6SS30/16	15	20		178	176	174	169	165	155	146	137	130	103	87	87	71	50	27	169~50	M:1230x150x150 B:1940x150x150	M:70.4 B:36.1		

Model	Power		Flow												Head Range (m)	Packing Dim(mm) Pump (L×W×H)	G.W. (kg)	Discharge (In)			
	Three-Phase	kW	HP	m³/h	0	6	12	18	24	30	36	42	48	54					60	66	72
				l/min	0	100	200	300	400	500	600	700	800	900					1000	1100	1200
6SS46/3	5.5	7.5		40	39	38	37	35	33	30	27	24	20	16	11	6	38~16	M:940x150x150 B:740x150x150	M:42.7 B:12.6	G3	
6SS46/5	7.5	10		66	65	64	62	59	55	50	45	40	33	26	19	10	63~26	M:1000x150x150 B:950x150x150	M:47.8 B:18.0		
6SS46/6	9.2	12.5	H(m)	79	78	77	74	71	66	60	54	48	40	31	23	12	76~31	M:1060x150x150 B:1070x150x150	M:53 B:20.7		
6SS46/7	11	15		92	91	90	87	83	77	70	63	56	46	36	27	14	89~36	M:1130x150x150 B:1190x150x150	M:61.2 B:23.4		
6SS46/8	13	17.5		106	104	103	99	94	88	80	72	64	52	41	30	16	101~41	M:1190x150x150 B:1310x150x150	M:67.3 B:26.1		
6SS46/9	15	20		119	117	115	112	106	99	90	81	72	59	47	34	18	114~47	M:1230x150x150 B:1420x150x150	M:70.4 B:28.8		

Model	Power		Flow														Head Range (m)	Packing Dim(mm) Pump (L×W×H)	G.W. (kg)	Discharge (In)	
	Three-Phase	kW	HP	m³/h	0	6	12	18	24	30	42	48	54	60	66	72					78
				l/min	0	100	200	300	400	500	700	800	900	1000	1100	1200					1300
6SS60/3	5.5	7.5		40	40	39	37	37	34	32	28	26	22	17	12	7	37~7	M:940x150x150 B:740x150x150	M:42.7 B:15.6	G3	
6SS60/4	7.5	10		54	53	52	51	49	46	40	38	34	30	23	16	9	51~9	M:1000x150x150 B:840x150x150	M:47.8 B:19.3		
6SS60/5	9.2	12.5	H(m)	67	66	65	64	61	57	50	47	43	37	29	20	11	64~11	M:1060x150x150 B:970x150x150	M:53 B:23.0		
6SS60/6	11	15		80	79	78	77	73	68	60	56	52	44	35	24	13	77~13	M:1130x150x150 B:1090x150x150	M:61.2 B:26.7		
6SS60/7	13	17.5		94	93	91	89	85	80	70	65	60	52	41	27	15	89~15	M:1190x150x150 B:1190x150x150	M:67.3 B:30.4		
6SS60/8	15	20		107	106	104	102	98	91	80	75	69	59	46	32	18	102~18	M:1230x150x150 B:1310x150x150	M:70.4 B:34.1		

NK(m)

Multi-stage Submersible Pumps

Application Limits

- Max. ambient temperature < 40°C ;
- Sand content (in mass fraction) up to 0.01%;
- Hydrogen sulfide content up to 1.5mg/L, chloride ion content up to 400mg/L;
- pH 6.5 to 8.5;
- Maximum: 20 m below the static water table.

Advantages & Features

- Single phase motor equipped with start box which built in capacitor & current mode thermal protector, convenient for replacement;
- Built-in motor, the suction pump body
- Installation in 5" or larger boreholes.

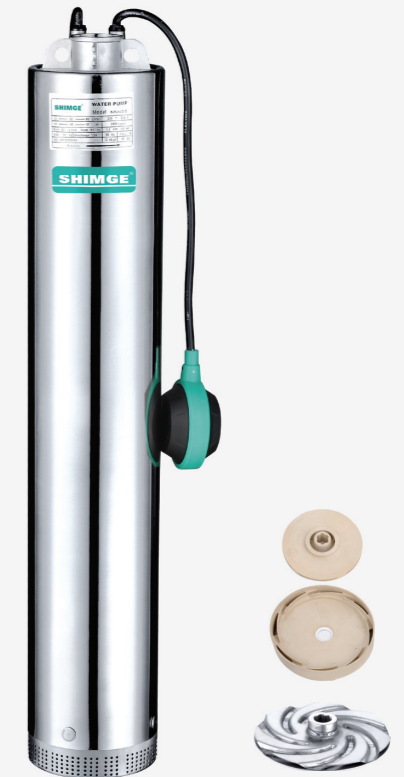

Performance Data

Model	Power		Flow										Head Range (m)	Packing Dim(mm) Pump(L×W×H)		G.W. (kg)			
	Single-Phase	Three-Phase	kW	HP	m³/h	0	1.2	1.8	2.4	3	3.6	4.2		4.8	5.4	Single-Phase	Three-Phase	Single-Phase	Three-Phase
					l/min	0	20	30	40	50	60	70		80	70				
NK3/3	-	-	0.55	0.75		33	31	30	28	25	21	17	11	5	31~11	555x140x230	-	15	-
NK3/4	NK3/4		0.75	1	H(m)	44	42	40	37	34	30	24	18	10	42~18	615x140x230	555x140x230	16.5	15
NK3/6	NK3/6		1.1	1.5		66	62	60	56	51	45	37	28	17	62~28	725x140x230	655x140x230	20	18
NK3/8	NK3/8		1.5	2		88	83	79	74	68	60	50	38	22	84~38	830x140x230	725x140x230	24	19

4P

Canned moter

Application Limits

- Dimension of connection conformity with 4 " NEMA (GM1-18.388)
- Rotation: CCW
- Degree of protection: IP68
- Insulation grade: Class F
- Min. cooling flow: 0.15m/s
- Max. Fluid temperature: 86 F(30°C)
- Max. number per hour of starts: 20
- Installation: vertical or horizontal
- Protection requirement: EN61947-4-1

Advantages & Features

- Kingsbury-type thrust bearing
- 17-4SS spline shaft
- All stainless steel canned motor
- Water lubricated bearings
- Auto water replenishing filter check valve
- Class H epoxy resin sealed motor
- Pressure-equalizing diaphragm
- Protection against sand and grit intrusion
- single-phase motor with control box
- Automatic thermal protection on single-phase motors



Performance Data

Motor Type	Type	Rating (50 HZ, 2870RPM)				In	Locked rotor	Eff.	Pf.	C		Thrust Load
		HP	KW	V	PH					A	A	
4PD	4PD0.37	1/2	0.37	220	1	2.7	7.3	63	98	18	/	3000
	4PD0.55	3/4	0.55	220		3.8	11.2	68	98	25	/	
	4PD0.75	1	0.75	220		5.1	16.3	68	99	25	/	
	4PD1.1	1 1/2	1.1	220		7.1	21.2	70	99	35	/	
	4PD1.5	2	1.5	220		9.6	32.5	72	98	45	/	
4P	4P0.37	1/2	0.37	380	3	1.0	3.7	65	80	/	/	
	4P0.55	3/4	0.55	380		1.5	6.4	70	77	/	/	
	4P0.75	1	0.75	380		1.9	8.6	71	80	/	/	
	4P1.1	1 1/2	1.1	380		2.7	13.6	74	79	/	/	
	4P1.5	2	1.5	380		3.8	18.9	74	78	/	/	
	4P2.2	3	2.2	380		5.2	26.3	76	81	/	/	
	4P0.37	1/2	0.37	220		1.8	6.4	65	80	/	/	
	4P0.55	3/4	0.55	220		2.5	11.0	70	77	/	/	
	4P0.75	1	0.75	220		3.3	14.9	71	80	/	/	
	4P1.1	1 1/2	1.1	220		4.7	23.6	74	79	/	/	
4PDS	4PDS0.75	1	0.75	220	1	5.5	30.4	67	94	25	150uf/330VAC	
	4PDS1.1	1 1/2	1.1	220		7.8	37.5	68	95	35	200uf/330VAC	
	4PDS1.5	2	1.5	220		10.5	52.7	70	94	40	250uf/330VAC	

QDX-L

Submersible Drainage Pumps



Application Limits

- Maximum liquid temperature +40°C
- pH level from 6.5-8.5
- Maximum sand content is 0.1%. Passage of suspended solids up to 0.2mm
- Power frequency is 50Hz. Nominal voltage is 220VAC for single phase and 380VAC for three phase with the range from -10% to 10%.
- Immersion depth from 0.5m-5m

Advantages & Features

- New-designed motor structure ,longer service life.
- Portable and durable aluminum alloy structure.
- Alloy impeller of high performance engineering plastics or aluminum.

Submersible Drainage Pumps

Performance Data

Model		Power		Rate Current (A)	Max. Flow (m³/h)	Max. Head (m)	Head Range (m)	Cable line (mm²-m)	Packing Dim. L × W × H(mm)	G.W (kg)	20'Loading Qty. (pcs)
Single-Phase	Three-Phase	kW	HP								
QDX1.5-12-0.25L2	-	0.25	0.33	2.1	4.5	14	5~13	3*0.75-8	360 × 160 × 200	5.3	2647
QDX1.5-17-0.37L2	-	0.37	0.5	2.9	6	18	4~18	3*0.75-8	380 × 160 × 200	7.2	2499
QDX1.5-25-0.55L2	-	0.55	0.75	4.1	6.5	26	17~26	3*0.75-8	395 × 195 × 220	9.5	1776
QDX3-18-0.55L2	-	0.55	0.75	4.1	8	20	5~20	3*0.75-8	410 × 195 × 220	9.5	1715
QDX10-12-0.55L2	-	0.55	0.75	4.1	15	18	7~15	3*0.75-8	410 × 210 × 220	9.9	1598
QDX15-7-0.55L2	-	0.55	0.75	4.1	24	9	2~9	3*0.75-8	410 × 210 × 220	9.5	1598
QDX1.5-32-0.75L2	-	0.75	1	5.2	8	33	17~32	3*0.75-8	410 × 210 × 225	11.5	1606
QDX3-24-0.75L2	-	0.75	1	5.2	9	25	14~25	3*0.75-8	410 × 195 × 230	11.5	1715
QDX8-18-0.75L2	-	0.75	1	5.2	15	20	15~19	3*0.75-8	420 × 195 × 230	11	1614
QDX10-16-0.75L2	-	0.75	1	5.2	15	20	10~19	3*0.75-8	420 × 195 × 230	11	1614
QDX15-10-0.75L2	-	0.75	1	5.2	36	12	3~11	3*0.75-8	420 × 220 × 240	11.5	1363
QDX25-6-0.75L2	-	0.75	1	5.2	35	11	0~8	3*0.75-8	420 × 220 × 260	11.5	1103
QDX30-6-0.75L2	-	0.75	1	5.2	45	11	0~8	3*0.75-8	450 × 280 × 225	13.5	1070
QDX3-30-1.1L2	-	1.1	1.5	7.3	10	31	0~30	3*1.5-8	455 × 280 × 215	14	1069
QDX14-16-1.1L2	-	1.1	1.5	7.3	29	18	14~18	3*1.5-8	470 × 280 × 215	16.5	1069
QDX15-14-1.1L2	-	1.1	1.5	7.3	29	18	0~17	3*1.5-8	470 × 280 × 215	17.5	990
QDX40-6-1.1L2	-	1.1	1.5	7.3	60	10	0~7.5	3*1.5-8	505 × 280 × 215	19	990
-	QX8-18-0.75L2	0.75	1	2	15	20	15~19	4*0.75-8	420 × 195 × 230	10.5	1262
-	QX10-16-0.75L2	0.75	1	2	15	20	10~19	4*0.75-8	420 × 195 × 230	10.5	1103
-	QX30-6-0.75L2	0.75	1	2	45	11	0~9	4*0.75-8	455 × 285 × 225	13	1069
-	QX3-30-1.1L2	1.1	1.5	2.7	10	31	0~30	4*0.75-8	455 × 280 × 215	12	1103
-	QX14-16-1.1L2	1.1	1.5	2.7	29	18	14~18	4*0.75-8	470 × 285 × 225	15	1069
-	QX15-14-1.1L2	1.1	1.5	2.7	29	18	0~17	4*0.75-8	470 × 280 × 215	15	1069
-	QX40-6-1.1L2	1.1	1.5	2.7	60	10	0~7.5	4*0.75-8	505 × 280 × 215	17	990
-	QX25-12-1.5L2	1.5	2	3.6	37	18	0~15	4*0.75-8	505 × 280 × 215	17	990
-	QX40-9-1.5L2	1.5	2	3.6	60	12	0~11	4*0.75-8	530 × 285 × 225	19	990

QDX-K3

Submersible Drainage Pumps



Application Limits

- ◎ Maximum liquid temperature +40°C
- ◎ pH level from 6.5-8.5
- ◎ Maximum sand content is 0.1%. Passage of suspended solids up to 0.2mm
- ◎ Power frequency is 50Hz. Nominal voltage is 220VAC for single phase and 380VAC for three phase with the range from -10% to 10%.
- ◎ Immersion depth from 0.5m-5m

Advantages & Features

- ◎ New-designed motor structure ,longer service life.
- ◎ Portable and durable aluminum alloy structure.
- ◎ Alloy impeller of high performance engineering plastics or aluminum.

Submersible Drainage Pumps

Performance Data

Model		Power		Rate Current (A)	Max. Flow (m³/h)	Max. Head (m)	Head Range (m)	Cable line (mm²-m)	Packing Dim. L×W×H(mm)	G.W (kg)	20'Loading Qty. (pcs)
Single-Phase	Three-Phase	kW	HP								
QDX1.5-12-0.25K3	-	0.25	0.33	2.1	4.5	13.0	5~13	3×0.75-8	360×180×200	18.5	2160
QDX1.5-17-0.37K3	-	0.37	0.5	2.9	9.5	18	7~18	3*0.75-8	380×160×200	8	2499
QDX1.5-25-0.55K3	-	0.55	0.75	4.1	5.5	25	15~26	3*0.75-8	395×180×220	10.5	1776
QDX3-18-0.55K3	-	0.55	0.75	4.1	8.0	21.0	5~21	3×0.75-8	410×210×220	12.5	1478
QDX10-12-0.55K3	-	0.55	0.75	4.1	18.0	17.0	5~16	3×0.75-8	410×210×220	8.5	1478
QDX15-7-0.55K3	-	0.55	0.75	4.1	25.0	9.0	3~9	3×0.75-8	410×210×220	11	1478
-	QX10-12-0.55K	0.55	0.75	1.6	18.0	17.0	5~16	4×0.75-8	410×210×220	13.5	1478
QDX1.5-32-0.75K3	-	0.75	1	5.2	6.5	34	12~33	3*0.75-8	420×210×230	12.5	1606
QDX3-24-0.75K3	-	0.75	1	5.2	7.5	26.0	14~26	3×0.75-8	410×195×220	13	1592
QDX8-18-0.75K3	-	0.75	1	5.2	16	20	15~19	3*0.75-8	420×195×230	13	1614
QDX10-16-0.75K3	-	0.75	1	5.2	19	20	10~19	3*0.75-8	420×195×230	13	1614
QDX30-6-0.75K3	-	0.75	1	5.2	47.0	8.0	2~8	3×0.75-8	450×280×210	11	1058
-	QX1.5-32-0.75K3	0.75	1	2	6.5	34.0	12~33	4×0.75-8	420×210×230	13.5	1380
-	QX3-24-0.75K3	0.75	1	2	7.5	26.0	14~26	4×0.75-8	410×195×220	13.5	1592
-	QX8-18-0.75K3	0.75	1	2	16.0	20.0	15~19	4×0.75-8	420×195×230	13	1486
-	QX10-16-0.75K3	0.75	1	2	19.0	20.0	10~19	4×0.75-8	420×195×230	11.5	1486
-	QX30-6-0.75K3	0.75	1	2	47.0	8.0	2~8	4×0.75-8	450×280×210	17	1058
QDX15-10-0.75K3	-	0.75	1	5.2	33.0	11.0	3~11	3×0.75-8	430×280×210	17	1107
QDX3-30-1.1K3	-	1.1	1.5	7.3	10.0	33.0	18~32	3×1-8	455×285×225	20	960
QDX6-25-1.1K3	-	1.1	1.5	7.3	12.0	30.0	8~29	3×1-8	455×285×225	11.5	960
QDX14-16-1.1K3	-	1.1	1.5	7.3	29.0	17.0	9~17	3×1-8	470×285×225	12	929
QDX15-14-1.1K3	-	1.1	1.5	7.3	30.0	17.0	9~17	3×1-8	470×285×225	12	929
QDX40-7-1.1K3	-	1.1	1.5	7.3	60.0	9.0	3~9	3×1-8	505×310×215	16	832
QDX15-18-1.5K3	-	1.5	2	9.5	38.0	20.0	8~19	3×1.5-8	505×280×215	11	921
QDX40-9-1.5K3	-	1.5	2	9.5	66.0	11.0	2~11	3×1.5-8	550×325×230	11.5	681
QDX50-7-1.5K3(with outlet of 4 inches)	-	1.5	2	9.5	77.0	11.0	2~11	3×1.5-8	550×325×230	11.5	681
-	QX3-30-1.1K3	1.1	1.5	2.7	10.0	33.0	18~32	4×0.75-8	455×285×225	12.5	960
-	QX6-25-1.1K3	1.1	1.5	2.7	12.0	30.0	8~29	4×0.75-8	455×285×225	15.5	960
-	QX14-16-1.1K3	1.1	1.5	2.7	29.0	17.0	9~17	4×0.75-8	470×285×225	15	929
-	QX15-14-1.1K3	1.1	1.5	2.7	30.0	17.0	9~17	4×0.75-8	470×285×225	18.5	929
-	QX40-7-1.1K3	1.1	1.5	2.7	60.0	9.0	3~9	4×0.75-8	505×310×215	17	832
-	QX15-18-1.5K3	1.5	2	3.6	40.0	20.0	8~19	4×0.75-8	505×280×215	23	921
-	QX40-9-1.5K3	1.5	2	3.6	66.0	11.0	2~11	4×0.75-8	550×325×230	23	681
-	QX50-7-1.5K3(with outlet of 4 inches)	1.5	2	3.6	77.0	11.0	2~11	4×0.75-8	550×325×230	15.5	681
-	QX25-12-1.5K3	1.5	2	3.6	45.0	16.0	5~15	4×0.75-8	490×285×225	13	891

QDX-T

Submersible Drainage Pumps

Application Limits

- Installing depth up to 5m
- Liquid temperature up to +40°C
- pH leve from 6.5-8.5
- Maximum sand content is 0.1%. Passage of suspended solids up to 0.2mm

Advantages & Features

- New appearance design, high quality life
- Anti-overloading motor design, not easy to burn machine
- Lightweight design, easy to maintenance;
- water from the bottom, extracting a lower water level;
- Adopt PPOG30 plastic impeller, durable;
- Stainless steel screws, easy to maintain;



Performance Data

Model	Power		Rate Current (A)	Max. Flow (m³/h)	Max. Head (m)	Head Range (m)	Cable line (m)	Packing Dim. L×W×H(mm)	G.W (kg)	20'Loading Qty. (pcs)
	kW	HP								
QDX1.5-17-0.37T	0.37	0.5	2.9	6	18	4~18	3*0.75-8	370×220×195	11.5	1760
QDX1.5-25-0.55T	0.55	0.75	4.1	5.7	26	17~26	3*0.75-8	455×285×225	15	980
QDX3-18-0.55T	0.55	0.75	4.1	7	21	5~20	3*0.75-8	450×280×225	15	980
QDX10-12-0.55T	0.55	0.75	4.1	17	20	10~19	3*0.75-8	450×280×210	17	1050
QDX15-7-0.55T	0.55	0.75	4.1	25.2	9	2~9	3*0.75-8	450×280×210	16.5	1050
QDX1.5-32-0.75T	0.75	1	5.2	6.9	33	17~32	3*0.75-8	450×280×225	17	980
QDX3-24-0.75T	0.75	1	5.2	7.2	26	14~25	3*0.75-8	455×285×225	17	950
QDX8-18-0.75T	0.75	1	5.2	17	20	15~19	3*0.75-8	450×280×210	17	1050
QDX10-16-0.75T	0.75	1	5.2	17	20	15~19	3*0.75-8	450×280×210	17	1050
QDX15-10-0.75T	0.75	1	5.2	35	12	3~11	3*0.75-8	450×280×210	18	1050
QDX30-6-0.75T	0.75	1	5.2	45	9	0~9	3*0.75-8	450×280×210	19	1050
QX1.5-32-0.75T	0.75	1	2	7	33	17~32	3*0.75-8	450×280×225	17	980
QX8-18-0.75T	0.75	1	2	16	20	15~19	3*0.75-8	450×280×210	17	1050
QX30-6-0.75T	0.75	1	2	44	7	0~7	3*0.75-8	450×280×210	19	1050
QX10-34-2.2	2.2	3.0	5.1	17	41	18~36	3*1-15	520×240×320	39	480
QX12.5-50-4	4.0	5.5	8.8	28	56	35~53	3x1.5+1x1☆-15	840×315×360	75	180
QX12.5-60-5.5	5.5	7.5	11.7	28	64	50~61	3x1.5+1x1☆-15	890×315×360	87	180

Centrifugal pumps are not recommended to be used less than the lift range.

QD

QD Multistage Multistage Submersible Pumps



Application Limits

- Maximum liquid temperature +40°C
- pH level from 6.5–8.5
- Maximum sand content is 0.1%. Passage of suspended solids up to 0.2mm
- Power frequency is 50Hz. Nominal voltage is 220VAC for single phase and 380VAC for three phase with the range from -10% to 10%.
- Immersion depth from 0.5m–5m

Advantages & Features

- High head, multistage centrifugal pump
- Compact structure, covering small area, convenient to move and use
- The angular contact ball bearing, improving the service life

Multistage Submersible Pumps

Performance Data

Model		Power		Rate Current (A)	Max. Flow (m³/h)	Max. Head (m)	Head Range (m)	Cable line (mm²-m)	Packing Dim. L × W × H (mm)	G.W (kg)	20' Loading Qty. (pcs)
Single-Phase	Three-Phase	kW	HP								
QD3-34/2-0.75	-	0.75	1	5.2	5	38	0-38	3*0.75-15	495x220x235	24	1170
QD3-50/3-1.1J	-	1.1	1.5	7.3	5	55	0-55	3*1-15	535x220x235	26	900
QD6-34/2-1.1J	-	1.1	1.5	7.3	14	37	20-37	3*1-15	535x220x235	27	900
QD6-34/2-1.1P	-	1.1	1.5	7.3	14	37	20-37	3*1-15	535x220x235	24	900
QD3-60/4-1.5J	-	1.5	2	9.5	5	66	0-66	3*1-15	610x220x235	31	810
QD6-35/2-1.5J	-	1.5	2	9.5	15	40	20-40	3*1-15	580x220x235	30	900
QD10-26/2-1.5J	-	1.5	2	9.5	20	30	0-30	3*1-15	580x220x235	30	900
QD10-32/3-1.5J	-	1.5	2	9.5	20	39	20-39	3*1-15	610x220x235	32	810
QD10-32/3-1.5P	-	1.5	2	9.5	20	39	20-39	3*1-15	610x220x235	29	810
QD15-20/2-1.5J	-	1.5	2	9.5	23	29	0-29	3*1-15	570x220x215	30	1000
QD3-85/5-1.8J	-	1.8	2.5	11.4	8	88	50-88	3*2-15	770x220x273	41	640
QD12-36/3-1.8J	-	1.8	2.5	11.4	21	43	10-40	3*2-15	670x205x275	38	640
QD3-98/6-2.2J	-	2.2	3	13.8	8	105	55-105	3*2-15	770x220x273	45	560
QD10-40/3-2.2J	-	2.2	3	13.8	23	44	0-43	3*2-15	705x220x273	40	640
-	Q3-34/2-0.75	0.75	1	2	5	38	0-38	4*0.75-15	495x220x235	22	990
-	Q3-34/2-0.75P	0.75	1	2	5	38	0-38	4*0.75-15	495x220x235	23	990
-	Q3-50/3-1.1J	1.1	1.5	2.7	5	55	0-55	4*0.75-15	525x220x215	25	900
-	Q6-34/2-1.1J	1.1	1.5	2.7	14	37	20-37	4*0.75-15	525x220x215	24	900
-	Q6-34/2-1.1P	1.1	1.5	2.7	14	37	20-37	4*0.75-15	525x220x215	23	900
-	Q3-60/4-1.5J	1.5	2	3.6	5	66	0-66	4*1-15	570x220x215	29	810
-	Q6-35/2-1.5J	1.5	2	3.6	15	40	20-40	4*1-15	525x220x215	27	900
-	Q10-26/2-1.5J	1.5	2	3.6	20	30	0-30	4*1-15	535x220x235	28	900
-	Q10-32/3-1.5J	1.5	2	3.6	20	39	20-36	4*1-15	580x220x235	30	810
-	Q10-32/3-1.5P	1.5	2	3.6	20	39	20-36	4*1-15	610x220x235	26	810
-	Q15-20/2-1.5J	1.5	2	3.6	23	29	0-29	4*1-15	525x220x215	26	1000
-	Q3-85/5-1.8J	1.8	2.5	4.3	8	88	50-88	4*1-15	740x220x273	37	640
-	Q12-36/3-1.8J	1.8	2.5	4.3	21	43	10-40	4*1-15	640x205x278	38	720
-	Q12-36/3-1.8P	1.8	2.5	4.3	21	43	10-40	4*1-15	640x205x278	36	720
-	Q3-98/6-2.2J	2.2	3	5.1	9.4	106	55-105	4*1-15	740x220x273	40	640
-	Q10-40/3-2.2J	2.2	3	5.1	23	44	0-43	4*1-15	610x215x278	36	720
-	Q3-116/7-3J	3	4	6.7	9	129	60-125	3*1.5+1*1-15	770x220x273	46	560
-	Q12.5-80/4-5.5L1	5.5	7.5	11.7	31	89	52-85	3*1.5 ☆ +1*1-24	1050x295x335	91	245
-	Q14-100/5-7.5L1	7.5	10	15.7	31	109	66-108	3*2.5+1*1.5-24	1190x295x320	105	196

Centrifugal pumps are not recommended to be used less than the lift range.
 Note: 0.75~ 1.5kw use honeycomb box. More than 1.8kw wooden cases.
 Q(D)-P seawater type for coastal customers

Q(D)Y-K2

Multistage Submersible Pumps



Application Limits

- Maximum liquid temperature +40°C
- pH level from 6.5–8.5
- Maximum sand content is 0.1%. Passage of suspended solids up to 0.2mm
- Power frequency is 50Hz. Nominal voltage is 220VAC for single phase and 380VAC for three phase with the range from –10% to 10%.
- Immersion depth from 0.5m–5m

Advantages & Features

- High head, multistage centrifugal pump
- Compact structure, covering small area, convenient to move and use
- The angular contact ball bearing, improving the service life

Multistage Submersible Pumps

Performance Data

Model		Power		Rate Current (A)	Max. Flow (m³/h)	Max. Head (m)	Head Range (m)	Cable line (mm²–m)	Packing Dim. L × W × H (mm)	G.W (kg)	20' Loading Qty. (pcs)
Single-Phase	Three-Phase	kW	HP								
QDY3-30/2-0.75K2	-	0.75	1	6.6	5.7	38	5~33	3*0.75-15	620 × 220 × 220	24	900
QDY3-45/3-1.1K2	-	1.1	1.5	8.6	5.7	55	5~47	3*1-15	680 × 220 × 220	27	800
QDY6-32/3-1.1K2	-	1.1	1.5	8.6	10	50	10~45	3*1-15	690 × 220 × 220	26.5	800
QDY3-55/4-1.5K2	-	1.5	2	11.2	5.7	67	5~65	3*1.5-15	750 × 235 × 245	26.5	800
QDY10-30/3-1.5K2	-	1.5	2	11.2	21	39	10~36	3*1.5-15	770 × 265 × 245	34	800
QDY15-21/3-1.5K2	-	1.5	2	11.2	21	37	10~36	3*1.5-15	770 × 235 × 240	34	800
QDY3-82/5-1.8K2	-	1.8	2.5	13.9	9	89	30~88	3*1.5-15 ☆	820 × 235 × 240	38	486
QDY12-36/4-1.8K2	-	1.8	2.5	13.9	21	52	5~50	3*1.5-15 ☆	850 × 235 × 240	37	486
QDY10-40/4-1.8K2	-	1.8	2.5	13.9	21	52	5~50	3*1.5-15 ☆	850 × 235 × 240	37.5	486
QDY3-96/6-2.2K2	-	2.2	3	16.2	9	108	30~104	3*1.5-15 ☆	870 × 235 × 240	40.5	486
QDY15-35/4-2.2K2	-	2.2	3	16.2	22	53	5~50	3*1.5-15 ☆	900 × 235 × 240	39.5	486
-	QY3-30/2-0.75K2	0.75	1	2.1	5.7	36	5~33	4*0.75-15	565 × 220 × 220	22	1000
-	QY3-45/3-1.1K2	1.1	1.5	2.9	5.7	55	5~47	4*0.75-15	630 × 185 × 185	21	900
-	QY6-32/3-1.1K2	1.1	1.5	2.9	10	50	10~45	4*0.75-15	600 × 185 × 185	23	900
-	QY3-55/4-1.5K2	1.5	2	3.8	5.7	67	5~65	4*0.75-15	655 × 220 × 220	24	800
-	QY10-30/3-1.5K2	1.5	2	3.4	21	39	10~36	4*0.75-15	655 × 220 × 220	24	800
-	QY15-21/3-1.5K2	1.5	2	3.4	21	37	10~36	4*0.75-15	670 × 220 × 220	24	800
-	QY3-82/5-1.8K2	1.8	2.5	4.5	9	89	30~88	4*0.75-15	750 × 235 × 240	32	567
-	QY12-36/4-1.8K2	1.8	2.5	4.5	21	52	5~50	4*0.75-15	770 × 235 × 240	34	567
-	QY10-40/4-1.8K2	1.8	2.5	4.5	21	52	5~50	4*0.75-15	770 × 235 × 240	34	567
-	QY3-96/6-2.2K2	2.2	3	5.4	9	108	30~104	4*1-15	820 × 235 × 240	35.5	567
-	QY15-35/4-2.2K2	2.2	3	5.4	25	50	5~50	4*1-15	820 × 235 × 240	37.5	486
-	QY3-112/7-3K2	3	4	7.2	10	127	30~120	4*1-15	870 × 235 × 240	38	486
-	QY20-36/2-3K1	3	4	7.2	34	46	30~40	3*1.5+1*1-15	750 × 290 × 325	50.5	392

Centrifugal pumps are not recommended to be used less than the lift range.
 Note: Single phase 0.75kw–1.1kw carton, 1.5 kw–1.5 kw should be packed in wooden cases;
 Three-Phase 0.75kw–1.5kw carton, 1.8 kw–3 kw should be packed in wooden cases

QY

Multistage Submersible Pumps



Application Limits

- Maximum liquid temperature +40°C
- pH level from 6.5–8.5
- Maximum sand content is 0.1%. Passage of suspended solids up to 0.2mm
- Power frequency is 50Hz. Nominal voltage is 380VAC for three phase with the range from –10% to 10%.
- Immersion depth from 0.5m–5m

Advantages & Features

- Wear-resistant whole cast iron parts design.
- Compact structure, easy to use.
- High quality double sides mechanical sealing to be reliable operating.

Multistage Submersible Pumps

Performance Data

Model	Power		Rate Current (A)	Max. Flow (m³/h)	Max. Head (m)	Head Range (m)	Cable line (mm²–m)	Packing Dim. L × W × H(mm)	G.W (kg)	20'Loading Qty. (pcs)	
	Single-Phase	kW									HP
QY15-26-2.2L3		2.2	3	5.4	28	30	0-30	4*1-15	630*260*315	48	504
QY25-17-2.2L3		2.2	3	5.4	30	20	0-20	4*1-15	630*260*315	48	504
QY65-7-2.2L3		2.2	3	5.4	80	10	0-10	4*1-8	685*235*290	49	504
QY100-4.5-2.2Z4		2.2	3	5.4	163	4.5	1.5-9.5	4*1-8	710*230*290	47	490
QY10-51/3-3L3		3	4	7.2	24.3	60	45-60	4*1-24	780*260*325	65	384
QY15-36-3L3		3	4	7.2	39.2	39	0-39	4*1-15	675*290*345	57	336
QY25-26-3L3		3	4	7.2	50.9	30	0-30	4*1-15	710*270*315	53	448
QY40-16-3L3		3	4	7.2	50	22	0-22	4*1-15	710*270*315	53	448
QY65-10-3L3		3	4	7.2	103	17	0-17	4*1-8	695*235*290	52	504
QY100-6-3Z4		3	4	7.2	175	6	1.5-6	3*1.5+10-8	735*230*295	54	504
QY160-4-3Z3		3	4	7.2	185	4	1.5-4	3*1.5+10-8	770*230*295	55	490
QY30-30-3.7L3		3.7	5	8.7	49	31	18-31	4*1-15	620*295*310	63	441
QY10-60/2-4L3		4	5.5	9.3	19.8	62	45-61	3*1.5+1*1-24	775*270*350	71	336
QY15-48/2-4L3		4	5.5	9.3	42	55	0-55	3*1.5+1*1-24	775*270*350	67	336
QY20-40/2-4L3		4	5.5	9.3	42	48	0-48	3*1.5+1*1-24	775*270*350	69	336
QY40-21-4L3		4	5.5	9.3	52	26	0-26	3*1.5+1*1-15	750*270*310	76	392
QY65-14-4L3		4	5.5	9.3	95	20	8-20	3*1.5+1*1-8	770*305*330	64	294
QY100-9-4L3		4	5.5	9.3	152	14	0-14	3*1.5+1*1-8	780*255*315	66	441
QY160-6-4Z3		4	5.5	9.3	225	10	2.5-6	3*1.5+1*1-8	780*255*315	59	420
QY200-4-4Z3		4	5.5	9.3	225	4	2.5-4	3*1.5+1*1-8	840*230*300	65	420
QY10-83/3-5.5L1		5.5	7.5	12.6	32	85	62-85	3*1.5+1*1-24	1050*330*400	113	150
QY15-68/4-5.5L1		5.5	7.5	12.6	28.3	88	28-87	3*1.5+1*1-24	935*320*370	99	252
QY25-40-5.5L1		5.5	7.5	12.6	68	43	33-43	3*1.5+1*1-24	775*340*395	81	210
QY40-28-5.5L1		5.5	7.5	12.6	72	34	19-34	3*1.5+1*1-15	770*335*385	83	252
QY65-18-5.5L2		5.5	7.5	12.6	140	19	0-19	3*1.5+1*1-15	845*295*380	90	252
QY100-13-5.5L1		5.5	7.5	12.6	148	19	0-19	3*1.5+1*1-15	845*295*380	92	252
QY160-8-5.5Z2		5.5	7.5	12.6	248	9	1.5-8	3*1.5+1*1-8	910*295*380	87	252
QY200-6-5.5Z1		5.5	7.5	12.6	240	6	0-6	3*1.5+1*1-8	885*295*380	91	252
QY250-5-5.5Z1		5.5	7.5	12.6	296	5	3.5-5	3*1.5+1*1-8	950*310*385	85	210
QY350-3.5-5.5Z1		5.5	7.5	12.6	400	10	2-3.5	3*1.5+1*1-8	950*310*385	91	210
QY10-110/4-7.5L1		7.5	10	16.8	32	115	84-115	3*2.5+1*1.5-24	1155*310*380	155	210
QY15-95/4-7.5L1		7.5	10	16.8	39	101	80-98	3*2.5+1*1.5-24	1155*310*380	136	210
QY18-84/4-7.5L1		7.5	10	16.8	38	94	70-88	3*2.5+1*1.5-24	1155*310*380	136	210
QY25-60/2-7.5L1		7.5	10	16.8	62	66	45-66	3*2.5+1*1.5-24	920*335*385	107	216
QY40-38-7.5L1		7.5	10	16.8	81	44	28-44	3*2.5+1*1.5-15	820*345*395	92	210
QY50-30-7.5L1		7.5	10	16.8	88	32	0-32	3*2.5+1*1.5-15	845*340*390	90	180
QY65-25-7.5L1		7.5	10	16.8	117	26	0-26	3 × 1.5+1 × 1 ☆ -15	845*295*380	101	252
QY80-20-7.5L1		7.5	10	16.8	128	24	0-24	3*2.5+1*1.5-15	845*295*380	101	252
QY100-17-7.5L1		7.5	10	16.8	125	22	0-22	3 × 1.5+1 × 1 ☆ -15	885*295*380	105	252
QY160-11-7.5Z1		7.5	10	16.8	200	11	2.5-11	3*2.5+1*1.5-8	990*295*380	111	210
QY200-9-7.5Z1		7.5	10	16.8	248	9	3-9	3*2.5+1*1.5-8	990*295*380	111	210
QY250-7-7.5Z1		7.5	10	16.8	323	7	3-7	3*2.5+1*1.5-8	950*310*385	97	210

Centrifugal pumps are not recommended to be used less than the lift range.
Axial flow pumps are not recommended to be used higher than the lift range.

Multistage Submersible Pumps

Performance Data

Model	Power		Rate Current (A)	Max. Flow (m³/h)	Max. Head (m)	Head Range (m)	Cable line (mm²-m)	Packing Dim. L × W × H (mm)	G.W (kg)	20'Loading Qty. (pcs)
	Single-Phase kW	HP								
QY10-165/6-11L1	11	15	24.3	31	170	130-170	3*4+1*2.5-24	1285*310*380	161	168
QY15-142/6-11L1	11	15	24.3	39.7	157	130-157	3*4+1*2.5-24	1295*305*375	161	168
QY18-126/6-11L1	11	15	24.3	35	138	105-130	3*4+1*2.5-24	1300*310*380	161	168
QY25-90/3-11L1	11	15	24.3	63	101	68-95	3*4+1*2.5-24	1050*330*400	129	180
QY40-56/2-11L1	11	15	24.3	80	65	0-65	3*4+1*2.5-24	920*335*385	113	216
QY65-42/2-11L1	11	15	24.3	114	54	0-54	3*4+1*2.5-24	980*340*390	117	150
QY100-25-11L1	11	15	24.3	160	40	0-40	3*4+1*2.5-15	910*365*385	110	216
QY160-15-11L1	11	15	24.3	240	25	10-20	3*4+1*2.5-8	980*315*390	105	175
QY350-7-11Z1	11	15	24.3	419	7	2.5-7	3*4+1*2.5-8	1020*310*385	108	180
QY450-6-11Z1	11	15	24.3	538	6	2-6	3*4+1*2.5-8	1130*360*395	120	130
QY600-4.5-11/4Z1	11	15	24.3	810	4.5	2-4.5	3*6+1*4+2*1-8	1360*500*530	200	60
QY25-120/4-15L1	15	20	33	63	135	100-132	3*6+1*4+2*1-24	1310*340*420	205	120
QY40-84/3-15L1	15	20	33	75	98	67-97	3*6+1*4+2*1-24	1120*340*420	183	120
QY65-60/3-15L1	15	20	33	111	82	48-78	3*6+1*4+2*1-24	1215*340*420	188	120
QY100-36-15L1	15	20	33	159	42	0-42	3*6+1*4+2*1-15	1020*400*460	167	120
QY160-23-15L1	15	20	33	248	39	0-39	3*6+1*4+2*1-15	1070*420*480	172	120
QY250-14-15L1	15	20	33	336	29	0-29	3*6+1*4+2*1-8	1185*340*440	171	120
QY600-6.5-15/4Z1	15	20	33	920	13	1-6.5	3*6+1*4+2*1-8	1430*500*530	231	50
QY15-200/8-18.5L1	18.5	25	42.4	34	212	0-212	3*6+1*4+2*1-24	1615*340*420	262	120
QY25-135/4-18.5L1	18.5	25	42.4	63	146	105-142	3*6+1*4+2*1-24	1355*340*420	215	120
QY65-69/3-18.5L1	18.5	25	42.4	111	87	0-87	3*6+1*4+2*1-24	1255*340*420	203	120
QY80-50-18.5L1	18.5	25	42.4	154	53	0-53	3*6+1*4+2*1-15	1070*400*460	180	125
QY160-28-18.5L1	18.5	25	42.4	264	42	0-42	3*6+1*4+2*1-15	1105*420*465	186	125
QY250-18-18.5	18.5	25	42.4	360	33	0-33	3*6+1*4+2*1-15	1225*340*440	186	120
QY800-6-18.5/4Z1	18.5	25	42.4	1000	13	1-6	3*6+1*4+2*1-8	1430*500*530	293	50
QY25-180/4-22L1	22	30	42.4	48	190	114-183	3*10+1*6+2*1-24	1455*350*420	271	120
QY40-114/3-22L1	22	30	42.4	80	127	70-127	3*10+1*6+2*1-24	1425*350*420	244	120
QY65-84/4-22L1	22	30	42.4	112	110	0-110	3*10+1*6+2*1-24	1375*350*420	235	120
QY200-26-22L1	22	30	42.4	360	38	0-38	3*10+1*6+2*1-15	1260*340*440	198	120
QY250-22-22L1	22	30	42.4	360	38	0-38	3*10+1*6+2*1-15	1260*340*440	198	120
QY800-7.5-22/4Z1	22	30	48.1	1000	13	1-7.5	3*10+1*6+2*1-8	1430*500*530	313	50

Centrifugal pumps are not recommended to be used less than the lift range.
Axial flow pumps are not recommended to be used higher than the lift range.

WVSD

WVS(D) Submersible Sewage Pumps

Application Limits

- Maximum liquid temperature +40°C
- pH level from 4-10
- Maximum liquid density 1.2 × 103 kg/m3
- Power frequency is 50Hz. Nominal voltage is 220VAC for single-phase and 380VAC with tolerance of ± 10%.
- Immersion depth from 0.5m-5m

Advantages & Features

- Stainless steel casing and rod bolts, beautiful, durable and stable.
- Opening impeller with good flow ability.
- The stainless steel shaft extension, carbide double sides mechanical sealing.



Performance Data

Model	Power		Rate Current (A)	Max. Flow (m³/h)	Max. Head (m)	Head Range (m)	Solids Passage (mm)	Cable line (m)	Dim.mm (L × W × H)	G.W (kg)	20'Loading Qty. (pcs)	
	Single-Phase	Three-Phase										
-	WVS75	0.75	1	2	21	12	11-5	40	4*0.75-5	260*190*500	18.5	1056
-	WVS110	1.1	1.5	2.7	27	13	12-7	40	4*0.75-5	285*205*505	21	880
-	WVS150	1.5	2	3.6	30	14	14-95	40	4*0.75-5	285*205*530	25	840
WVSD55F	-	0.55	0.75	4.1	18	10	9-4	40	3*0.75-5	260*190*480	17	1056
WVSD75F	-	0.75	1	5.2	21	12	11-5	40	3*1-5	260*190*500	19	1056
WVSD110F	-	1.1	1.5	7.3	27	13	12-7	40	3*1.5-5	285*205*505	23	880
WVSD150F	-	1.5	2	9.5	30	14	14-5	40	3*1.5-5	285*205*530	25.5	840
WVSD55A2F	-	0.55	0.75	4.1	18	13	10-4	10	3*0.75-5	260*190*450	17	1320
WVSD75A2F	-	0.75	1	5.2	20	15	14-5	10	3*1-5	260*190*470	19	1056
-	WVS75A2	0.75	1	2	20	15	14-5	10	4*0.75-5	260*190*470	19	1056

Centrifugal pumps are not recommended to be used less than the lift range.

WQK

WQK Submersible Pump For Dirty Water

Application Limits

- Maximum liquid temperature +40°C
- pH level from 4-10
- Maximum liquid density 1.2 × 103 kg/m3
- Power frequency is 50Hz. Nominal voltage 380VAC or 415VAC for three phase with the range from -10% to 10%.
- Immersion depth from 0.5m-5m

Advantages & Features

- The durable whole cast iron parts design.
- The shaft material are all of stainless steel material 2Cr13 carbide double sides mechanical sealing.
- Cutting impeller, objects can be cut up.
- Can be configured coupling bend, the water festival and directly connected with pipe thread or NPT threaded pipe bending.



WQD-L

WQD Submersible Pump For Dirty Water



WQ(D)-L1
0.55 ~ 7.5kW,
Centrifugal impeller



WQ(D)-X
0.55 ~ 1.1kW,
Semi-open impeller

Performance Data

* Note:WQK9.6-10/15-12 with dat-50a coupling device.
* WQK36-22/48-25 with dat-100a coupling device.

* WQK18-15/30-18 with dat-80a coupling device.

Model	Power		Rate Current (A)	Max. Flow (m³/h)	Max. Head (m)	Head Range (m)	Solids Passage (mm)	Cable line (m)	Dim.mm (L×W×H)	G.W (kg)	20' Loading Qty. (pcs)
	kW	HP									
WQK9.6-10-0.75(380V/50Hz)	0.75	1	2	23.5	13	8-12	20	4*0.75-6	525×250×305	34	693
WQK15-12-1.5(380V/50Hz)	1.5	2	3.6	31	19	9-15	20	4*1-6	600×255×330	42.3	567
WQK18-15-2.2(380V/50Hz)	2.2	3	5.1	64	20	12-18	20	4*1-6	600×275×365	51.7	486
WQK30-18-3.7(380V/50Hz)	3.7	5	8.2	80	23	14-22	30	4*1.5-6	370×325×680	71	324
WQK36-22-5.5(380V/50Hz)	5.5	7.5	11.7	100	28	17-27	30	4*1.5 ☆ -6	400×340×770	85	255
WQK48-25-7.5(380V/50Hz)	7.5	10	15.7	102	33	20-30	30	4*2.5-6	400×340×770	91	255
WQK15-12-1.5(415V/50Hz)	1.5	2	3.3	31	19	9-15	20	4*1-6	600×255×330	42.3	567
WQK18-15-2.2(415V/50Hz)	2.2	3	4.7	69	20	12-18	20	4*1-6	600×275×365	51.7	486

Centrifugal pumps are not recommended to be used less than the lift range.

Application Limits

- Maximum liquid temperature +40°C
- pH level from 4-10
- Maximum liquid density 1.2 × 103kg/m3
- Power frequency is 50Hz. Nominal voltage is 220VAC for single phase and 380VAC for three phase with the range from -10% to 10%.
- Immersion depth from 0.5m-5m

Advantages & Features

- The whole cast iron design, wear-resistant, durable and nice appearance.
- Double channel impeller, good flow capacity, excellent hydraulic performance.
- Stainless steel shaft extension, carbide double-sides mechanical sealing.

WQD Submersible Pump For Dirty Water

Performance Data

Model		Power		Rate Current (A)	Solids Passage (mm)	Max. Flow (m³/h)	Max. Head (m)	Head Range (m)	Cable line (m)	Dim.mm (L x W x H)	G.W (kg)	20' Loading Qty. (pcs)
Single-Phase	Three-Phase	kW	HP									
WQD6-12-0.55L3	-	0.55	0.75	4.1	20	17	15	0~14	3*0.75-8	470×250×235	18.5	1080
WQD6-16-0.75L3	-	0.75	1	5.2	20	18	19	9~19	3*0.75-8	470×250×235	20	1080
WQD10-10-0.75L1	-	0.75	1	5.2	20	24	15	0~15	3*0.75-8	470×250×235	22	1080
WQD7-15-1.1L1	-	1.1	1.5	7.3	20	23	19	3~18	3*1-8	550×245×295	31	960
WQD15-9-1.1L1	-	1.1	1.5	7.3	20	25.5	14.5	0~14.5	3*1-8	550×245×295	30	1080
WQD6-12-0.55L3(F)	-	0.55	0.75	4.1	20	19	15	0~15	3*0.75-8	470×250×235	18.5	1080
WQD6-16-0.75L3(F)	-	0.75	1	5.2	20	18	19	9~19	3*0.75-8	470×250×235	20	1080
WQD10-10-0.75L1(F)	-	0.75	1	5.2	20	17	16	0~16	3*0.75-8	470×250×235	22	1080
WQD10-10-0.75L1(FL)	-	0.75	1	5.2	20	17	16	0~16	3*0.75-8	520×210×275	26	968
WQD7-15-1.1L1(FL)	-	1.1	1.5	7.3	20	23	19	3~18	3*1-8	550×245×235	34	1080
WQD15-9-1.1L1(FL)	-	1.1	1.5	7.3	20	25.5	14.5	0~14.5	3*1-8	450×245×275	33	1080
-	WQ6-16-0.75L3	0.75	1	2	20	16	19	9~19	4*0.75-8	470×250×235	19	1080
-	WQ10-10-0.75L1	0.75	1	2	20	24	15	0~16	4*0.75-8	470×250×235	23	968
-	WQ15-7-0.75L1	0.75	1	2	20	17	17	0~17	4*0.75-8	520×210×275	23	968
-	WQ7-15-1.1L1	1.1	1.5	2.7	20	22	18	3~18	4*0.75-8	550×245×295	34	960
-	WQ15-9-1.1L1	1.1	1.5	2.7	20	24	14	0~14	4*0.75-8	550×245×295	28	960
-	WQ25-7-1.1L1	1.1	1.5	2.7	25	38	14	0~14	4*0.75-8	550×245×295	29	960
-	WQ12-15-1.5L1	1.5	2	3.6	20	37	20	0~20	4*0.75-15	550×245×295	31	960
-	WQ18-15-1.5L1	1.5	2	3.6	20	47	20	0~20	4*0.75-15	610×260×308	45	960
-	WQ25-10-1.5L1	1.5	2	3.6	25	40	19	0~19	4*0.75-8	550×245×295	30	960
-	WQ9-22-2.2L1	2.2	3	5.1	20	32	26	0~26	4*1-15	630×285×345	47	432
-	WQ15-20-2.2L1	2.2	3	5.1	20	34	25	0~25	4*1-15	630×285×345	46	432
-	WQ25-15-2.2L1	2.2	3	5.1	25	59	21.5	0~21.5	4*1-15	630×285×345	57	432
-	WQ35-7-2.2L1	2.2	3	5.1	25	50	15.5	0~15.5	4*1-8	630×285×345	51	432
-	WQ42-9-2.2L1	2.2	3	5.1	25	59	22	0~22	4*1-8	630×285×345	51	432
-	WQ15-30-3L3	3	4	6.7	25	30	33	20~33	3*1.5+1×1-15	680×285×345	59	384
-	WQ20-22-3L3	3	4	6.7	25	48	27	10~28	3*1.5+1×1-8	680×285×345	61	384
-	WQ25-20-3L3	3	4	6.7	25	48	27	10~25.5	3*1.5+1×1-8	680×285×345	61	384
-	WQ43-13-3L3	3	4	6.7	25	82	18.5	0~18.5	3*1.5+1×1-8	700×310×370	68	342
-	WQ50-10-3L3	3	4	6.7	25	82	18.5	0~18.5	3*1.5+1×1-8	700×310×370	68	342
-	WQ70-7-3L3	3	4	6.7	25	93	20	0~20	3*1.5+1×1-15	715×345×415	63	255
-	WQ20-27-4L1	4	5.5	8.8	25	40	36	0~36	3×1.5+1×1-8	710×350×380	63	255

Centrifugal pumps are not recommended to be used less than the lift range.

WQD Submersible Pump For Dirty Water

Performance Data

Model		Power		Rate Current (A)	Solids Passage (mm)	Max. Flow (m³/h)	Max. Head (m)	Head Range (m)	Cable line (m)	Dim.mm (L x W x H)	G.W (kg)	20' Loading Qty. (pcs)
Single-Phase	Three-Phase	kW	HP									
-	WQ40-15-4L1	4	5.5	8.8	25	91	22	0~22	3*1.5+1*1-8	745×345×415	73	255
-	WQ60-10-4L1	4	5.5	8.8	25	91	20.5	0~20.5	3*1.5+1*1-8	745×345×415	73	255
-	WQ15-40-5.5L1	5.5	7.5	11.7	25	50	42.5	0~44	3*1.5+1*1☆-15	750×340×380	89	306
-	WQ30-30-5.5L1	5.5	7.5	11.7	25	50	42.5	0~42.5	3*1.5+1*1☆-15	750×310×380	97	306
-	WQ65-15-5.5L1	5.5	7.5	11.7	30	118	27	0~27	3*1.5+1*1☆-8	810×340×410	96	201
-	WQ40-30-7.5L1	7.5	10	15.7	25	53	43	0~43	3×1.5+1×1☆-8	800×355×410	102	210
-	WQ45-22-7.5L1	7.5	10	15.7	30	97	32	0~32	3×1.5+1×1☆-8	845×355×415	109	180
-	WQ65-20-7.5L1	7.5	10	15.7	30	143	27.5	0~27.5	3×1.5+1×1☆-8	845×355×415	109	180
-	WQ80-15-7.5L1	7.5	10	15.7	30	143	27.5	0~27.5	3×1.5+1×1☆-8	845×355×425	109	180
-	WQ100-10-7.5L1	7.5	10	15.7	30	143	27.5	0~27.5	3×1.5+1×1☆-8	845×355×415	109	180
-	WQ10-10-0.75L1(FL)	0.75	1	2	20	17	16	0~16	4*0.75-8	520×210×275	25	968
-	WQ15-7-0.75L1(FL)	0.75	1	2	20	17	17	0~17	4*0.75-8	520×210×275	23	968
-	WQ7-15-1.1L1(FL)	1.1	1.5	2.7	20	22	18	3~18	4*0.75-8	550×245×295	33	1080
-	WQ15-9-1.1L1(FL)	1.1	1.5	2.7	20	24	14	0~14	4*0.75-8	550×245×295	31	1080
-	WQ25-7-1.1L1(FL)	1.1	1.5	2.7	20	38	14	0~14	4*0.75-8	550×245×295	32	1080
-	WQ12-15-1.5L1(FL)	1.5	2	3.6	20	37	20	0~20	4*0.75-15	550×245×295	34	1080
-	WQ18-15-1.5L1(FL)	1.5	2	3.6	20	40	20	0~20	4*0.75-15	550×245×295	31	1080
-	WQ25-10-1.5L1(FL)	1.5	2	3.6	25	40	19	0~19	4*0.75-8	550×245×295	30	1080
WQD10-8-0.55X	-	0.55	0.75	4.1	13	19	12	0~12	3*0.75-8	480×230×215	18	1080
WQD6-16-0.75X	-	0.75	1	5.2	14	22	17	9~17	3*0.75-8	470×250×235	21	1080
WQD10-11-0.75X	-	0.75	1	5.2	14	21	16	0~16	3*0.75-8	450×230×215	19	1080
WQD15-12-1.1X	-	1.1	1.5	7.3	15	26	16	0~16	3*1-8	550×245×295	30	960
-	WQ6-16-0.75X	0.75	1	2	14	22	17	9~17	4*0.75-8	450×230×215	21	1080
-	WQ10-11-0.75X	0.75	1	2	14	21	16	0~16	4*0.75-8	450×230×215	20.5	1080
-	WQ15-12-1.1X	1.1	1.5	2.7	15	26	16	0~16	4*0.75-8	550×245×280	29	960

Centrifugal pumps are not recommended to be used less than the lift range.
Note:0.55kW~0.75kW is the honeycomb box, the rest are wooden cases.

WQ(D)

WQ(D) Submersible Pump For Dirty Water



Application Limits

- Maximum liquid temperature +40°C
- pH level from 4-10
- Maximum liquid density 1.2 × 103 kg/m3
- Power frequency is 50Hz. Nominal voltage is 220VAC for single phase and 380VAC or 415VAC for three phase with the range from -10% to 10%.
- Immersion depth from 0.5m-5m

Advantages & Features

- Wear-resistant whole cast iron parts design
- Double channel impeller, good flow capacity, excellent hydraulic performance
- The stainless steel shaft extension, carbide double sides mechanical sealing

WQ(D) Submersible Pump For Dirty Water

Performance Data

Single-Phase	Three-Phase	Power		Rate Current (A)	Solids Passage (mm)	Max. Flow (m³/h)	Max. Head (m)	Head Range (m)	Cable line (m)	Dim. mm (L × W × H)	G.W (kg)	20' Loading Qty. (pcs)
		kW	HP									
WQD6-12-0.55	-	0.55	0.75	4.1	20	17.5	15	14-0	3*0.75-8	470 × 250 × 235	20	1150
WQD6-16-0.75	-	0.75	1	5.2	20	22	19	18-5	3*0.75-8	470 × 250 × 235	22	1150
WQD6-16-0.75F	-	0.75	1	5.2	20	22	19	18-5	3*0.75-8	470 × 250 × 235	22	1150
WQD10-10-0.75	-	0.75	1	5.2	20	24	15	15-0	3*0.75-8	520 × 210 × 275	29	968
WQD7-15-1.1	-	1.1	1.5	7.3	20	22	19	18-3	3*1-8	540 × 240 × 280	31	1150
WQD15-9-1.1	-	1.1	1.5	7.3	20	25	14	14-0	3*1-8	540 × 240 × 280	32	968
WQD6-12-0.55F	-	0.55	0.75	4.1	20	17.5	15	14-0	3*0.75-8	470 × 250 × 235	20	1150
-	WQ6-16-0.75	0.75	1	2	20	22	19	18-8	4*0.75-8	470 × 250 × 235	29	968
-	WQ10-10-0.75	0.75	1	2	20	24	15	15-0	4*0.75-8	540 × 240 × 280	31	768
-	WQ15-7-0.75	0.75	1	2	20	17	17	17-0	4*0.75-8	540 × 240 × 280	32	768
-	WQ7-15-1.1	1.1	1.5	2.7	20	22	19	18-3	4*0.75-8	540 × 240 × 280	27	768
-	WQ15-9-1.1	1.1	1.5	2.7	20	25	14	14-0	4*0.75-8	540 × 240 × 280	32	768
-	WQ12-15-1.5	1.5	2	3.6	20	34	20	20-0	4*0.75-15	610 × 260 × 308	40	567
-	WQ18-15-1.5	1.5	2	3.6	20	47	19	20-0	4*0.75-15	610 × 260 × 308	45	567
-	WQ25-10-1.5	1.5	2	3.6	25	42	15	19-0	4*0.75-8	610 × 260 × 308	42	567
-	WQ25-7-1.5	1.5	2	3.6	25	40	14	14-0	4*0.75-8	610 × 260 × 308	39	567
-	WQ9-22-2.2	2.2	3	5.1	20	29	25	26-0	4*1-15	635 × 260 × 348	47	486
-	WQ15-20-2.2	2.2	3	5.1	20	35	25	24-0	4*1-15	635 × 260 × 348	47.7	486
-	WQ25-15-2.2	2.2	3	5.1	20	60	20	20-0	4*1-15	635 × 260 × 348	50	486
-	WQ27-15-2.2	2.2	3	5.1	28	62	21	19-5	4*1-15	635 × 260 × 348	50	486
-	WQ35-7-2.2	2.2	3	5.1	30	50	15	15-0	4*1-8	635 × 260 × 348	50	486
-	WQ42-9-2.2	2.2	3	5.1	25	60	16	19-0	4*1-8	655 × 270 × 328	50	504
-	WQ15-30-3	3	4	6.7	25	31	34	34-20	3*1.5+1*1-15	635 × 260 × 348	50	486
-	WQ20-22-3	3	4	6.7	25	45	27	26-10	3*1.5+1*1-15	635 × 260 × 348	54	486
-	WQ25-20-3	3	4	6.7	25	48	25	25-10	3*1.5+1*1-15	635 × 260 × 348	54	486
-	WQ37-13-3	3	4	6.7	25	77	20	18-0	3*1.5+1*1-8	720 × 320 × 390	56.5	336
-	WQ43-13-3	3	4	6.7	25	82	18.5	18-0	3*1.5+1*1-8	700 × 310 × 370	68	336
-	WQ50-7-3	3	4	6.7	32	72	13	13-0	3*1.5+1*1-8	720 × 320 × 390	62	336
-	WQ50-10-3	3	4	6.7	25	84	19	19-0	3*1.5+1*1-8	720 × 320 × 390	62	336
-	WQ40-15-4	4	5.5	8.8	25	70	22	22-0	3*1.5+1*1-8	755 × 325 × 395	80	324
-	WQ60-10-4	4	5.5	8.8	43	92	18	18-0	3*1.5+1*1-8	800 × 335 × 395	83	294
-	WQ15-40-5.5	5.5	7.5	11.7	25	52	42.5	42.5-0	3*1.5+1*1 ☆-8	755 × 325 × 395	85	324
-	WQ30-30-5.5	5.5	7.5	11.7	25	39	37	37-0	3*1.5+1*1 ☆-15	800 × 320 × 380	88	294
-	WQ65-15-5.5	5.5	7.5	11.7	30	110	25	26-0	3*1.5+1*1 ☆-8	1050 × 345 × 325	103	175
-	WQ65-20-7.5	7.5	10	15.7	30	140	27	27-0	3 × 1.5+1 × 1 ☆-15	870 × 430 × 520	128	120
-	WQ80-15-7.5	7.5	10	15.7	30	140	27	27-0	3 × 1.5+1 × 1 ☆-8	870 × 430 × 520	128	120
-	WQ100-10-7.5	7.5	10	15.7	30	140	27	27-0	3 × 1.5+1 × 1 ☆-8	1100 × 395 × 395	131	120
-	WQ6-16-0.75(415V/50Hz)	0.75	1	1.8	20	22	19	18-5	4*0.75-8	470 × 250 × 235	21	1150
-	WQ18-15-1.5(415V/50Hz)	1.5	2	3.3	20	47	19	19-0	4*0.75-15	610 × 260 × 308	45	567
-	WQ25-15-2.2(415V/50Hz)	2.2	3	4.7	20	60	20	20-0	4*1-15	635 × 260 × 348	50	486
-	WQ25-20-3(415V/50Hz)	3	4	6.1	25	48	25	25-10	3*1.5+1*1-15	635 × 260 × 348	54	486
-	WQ50-10-3(415V/50Hz)	3	4	6.1	25	84	19	19-0	3*1.5+1*1-8	720 × 320 × 390	62	336
-	WQ40-15-4(415V/50Hz)	4	5.5	8.1	25	70	22	22-0	3*1.5+1*1-8	755 × 325 × 395	80	324
-	WQ60-10-4(415V/50Hz)	4	5.5	8.1	43	92	18	18-0	3*1.5+1*1-8	800 × 335 × 395	83	324
-	WQ65-15-5.5(415V/50Hz)	5.5	7.5	10.7	30	110	25	26-0	3*1.5+1*1 ☆-8	1050 × 345 × 325	103	175
-	WQ100-10-7.5(415V/50Hz)	7.5	10	14.4	30	140	21	27-0	3*2.5+1*1.5-8	870 × 430 × 520	131	120

Centrifugal pumps are not recommended to be used less than the lift range.

Note: Single-Phase:WQD6-12-0.55/WQD6-16-0.75/WQD6-16-0.75F is the honeycomb carton; Three-Phase:WQ6-16-0.75 is the honeycomb carton.The others are wooden cases.

WQ

WQ Submersible Pump For Dirty Water

Application Limits

- Maximum liquid temperature +40°C
- pH level from 4-10
- Maximum liquid density $1.2 \times 103 \text{ kg/m}^3$
- Voltage fluctuation range $\pm 10\%$
- Immersion depth from 0.5m-5m

Advantages & Features

- Large power submersible sewage pump, the standard flange outlet.
- Double channel impeller, good flowing capacity, excellent hydraulic performance.
- Stainless steel shaft extension and carbide double sides mechanical sealing.

Performance Data

Model	Power		Rate Current (A)	Solids Passage (mm)	Max. Flow (m ³ /h)	Max. Head (m)	Head Range (m)	Cable line (m)	Dim.mm (L x W x H)	G.W (kg)	20' Loading Qty. (pcs)
	Single-Phase	kW									
WQ100-23-11	11	15	22.9	35	175	29	15-29	3*6+1*4-8	600 x 560 x 1230	253	69
WQ130-15-11	11	15	22.9	45	330	22	0-22	3*6+1*4-8	590 x 500 x 1290	256	76
WQ150-13-11	11	15	22.9	45	320	18	0-18	3*6+1*4-8	590 x 500 x 1290	253	76
WQ180-11-11	11	15	22.9	50	300	20	0-20	3*6+1*4-8	590 x 500 x 1290	253	76
WQ300-6-11	11	15	22.9	60	540	10	0-10	3*6+1*4-8	620 x 560 x 1450	281	55
WQ360-6-11	11	15	22.9	60	540	10	0-10	3*6+1*4-8	620 x 560 x 1450	281	55
WQ100-30-15	15	20	30.8	35	190	33	0-33	3*6+1*4-8	600 x 560 x 1230	270	69
WQ150-17-15	15	20	30.8	45	350	25	0-25	3*6+1*4-8	590 x 500 x 1290	268	76
WQ180-15-15	15	20	30.8	50	320	23	0-23	3*6+1*4-8	590 x 500 x 1290	268	76
WQ250-11-15	15	20	30.8	50	400	20	0-20	3*6+1*4-8	660 x 570 x 1380	298	55
WQ400-7-15	15	20	30.8	65	620	14	0-14	3*6+1*4-8	620 x 560 x 1450	312	55
WQ100-32-18.5	18.5	25	37.2	35	224	37	20-37	3*10+1*6-8	690 x 600 x 1300	338	54
WQ150-20-18.5	18.5	25	37.2	45	350	28	0-28	3*10+1*6-8	640 x 570 x 1350	356	61
WQ180-20-18.5	18.5	25	37.2	45	400	28	0-28	3*10+1*6-8	640 x 570 x 1350	365	61
WQ250-15-18.5	18.5	25	37.2	50	400	22	0-22	3*10+1*6-8	660 x 610 x 1450	372	48
WQ350-10-18.5	18.5	25	37.2	55	520	17	0-17	3*10+1*6-8	620 x 560 x 1525	370	55
WQ100-37-22	22	30	49.4	35	249	44	25-44	3*10+1*6-8	690 x 600 x 1300	351	54
WQ130-30-22	22	30	49.4	45	320	35	0-35	3*10+1*6-8	690 x 600 x 1300	351	54
WQ180-25-22	22	30	49.4	45	340	32	0-32	3*10+1*6-8	640 x 570 x 1350	366	61
WQ250-18-22	22	30	49.4	50	450	27	0-27	3*10+1*6-8	660 x 610 x 1450	377	48
WQ400-10-22	22	30	49.4	60	630	18	0-18	3*10+1*6-8	620 x 560 x 1525	385	55

Centrifugal pumps are not recommended to be used less than the lift range.



WQ-QG

WQ-QG Disc - Type Sewage - Cutting Submerged Electric Pump



Application Limits

- The operating temperature is 0-40°C, and the temperature of pumped medium should not exceed +40°C;
- The pH value (i.e. acidity or alkalinity) of pumped medium is 4-10;
- The density of medium is $1.2 \times 10 \text{ kg/m}^3$ at maximum;
- The rated frequency of AC power supply is 50Hz, the rated voltage is three-phase 380V, and the fluctuation range of voltage is $\pm 10\%$ of the rated value;
- The immersion depth should be between 0.5m and 5m.

Advantages & Features

- Corrosion-resistant alloy cutter, avoiding jamming caused by rusting even after stopping for a long time during use;
- Screw impeller, which is wear-resistant, anti-clogging, and anti-winding;
- A new-type cable sealing structure is adopted to achieve good sealing effect, avoiding burning-out caused by leakage;
- Two single mechanical seals are adopted to achieve good sealing effect, and it is more reliable and durable than framework oil seal;

Performance Data

Model		Power		Rate Current (A)	Max. Flow (m³/h)	Max. Head (m)	Head Range (m)	Cable line (m)	Dim.mm (L×W×H)	G.W (kg)	20'Loading Qty. (pcs)
Single-Phase	Three-Phase	kW	HP								
-	50WQ0.75QG	0.75	1	2	13.8	15.5	4~14	4*0.75-8	600*230*220	25	922
-	50WQ1.1QG	1.1	1.5	2.7	13.8	19.5	5~18	4*0.75-8	600*230*220	26	922
-	50WQ1.5QG	1.5	2	3.6	25	16	5~16	4*0.75-8	615*225*290	37	522
-	50WQ2.2QG	2.2	3	5.1	29.4	32	10~30	4*0.75-8	615*230*300	42	660
-	65WQ2.2QG	2.2	3	5.1	40	20	5~20	4*0.75-8	620*260*340	38	483
-	50WQ3QG	3	4	6.7	39.6	28	10~28	4*1-8	690*230*310	55	569
-	65WQ3QG	3	4	6.7	55	20	5~20	4*1-8	685*240*330	51	386
-	65WQ4QG	4	5.5	8.8	63	33	10~30	3*1.5+1*1-8	700*240*350	60	476
-	80WQ4QG	4	5.5	8.8	80	22	5~22	3*1.5+1*1-8	685*260*360	57	344
-	80WQ5.5QG	5.5	7.5	11.7	86.4	29	10~28	3*1.5+1*1-8	770*300*390	82	311
-	100WQ5.5QG	5.5	7.5	11.7	95	24	5~24	3*1.5+1*1-8	750*320*415	87	228
-	80WQ7.5QG	7.5	10	15.7	93.6	35.5	10~35	3*2.5+1*1.5-8	770*300*390	82	311
-	100WQ7.5QG	7.5	10	15.7	135	26	5~26	3*2.5+1*1.5-8	780*330*435	97	204
50WQD0.75QG	-	0.75	1	5.2	13.8	15.5	4~14	3*0.75-8	600*230*220	26	922
50WQD1.1QG	-	1.1	1.5	7.3	13.8	19.5	5~18	3*0.75-8	600*230*220	27	922
50WQD1.5QG	-	1.5	2	9.5	25.02	16	5~16	3*1-8	645*225*290	44	665
50WQD2.2QG	-	2.2	3	13.5	35.4	32	10~30	3*1.5-8	650*230*300	46	624
65WQD2.2QG	-	2.2	3	13.5	40.02	20	5~20	3*1.5-8	650*270*340	47	469

BL/BLT

Vertical Multi-Stage Centrifugal Pumps



Application Limits

- ⊙ Medium temperature: normal type:0°C ~68°C ,hot water type:0°C ~120°C ,
- ⊙ Maximum ambient temperature:+40°C ,
- ⊙ Maximum ambient pressure:1.0MPa,
- ⊙ When pumping liquids with a density and/or viscosity higher than that of water,use motors with correspondingly higher outputs,if required.
- ⊙ pH: 5 to 9

Vertical Multi-Stage Centrifugal Pumps

Performance Data

Model	Power		Caliber	Q (m³/h)	1	1.2	1.6	2	2.4	2.8	3.2	Head Range (m)	Packing Dim. (L×W×H) mm	G.W.(kg)	
	kW	HP												BL	BLT
BL(T)2-2	0.37	0.5	DN25 (1 1/4')	H (m)	18	17	16	15	13	12	10	10~18	590×330×320	25	30
BL(T)2-3	0.37	0.5			27	26	24	22	20	18	15	15~27	590×330×320	25	30
BL(T)2-4	0.55	0.75			36	35	33	30	26	24	20	20~36	630×330×320	28	32
BL(T)2-5	0.55	0.75			45	43	40	37	33	30	24	24~45	630×330×320	28	33
BL(T)2-6	0.75	1			53	52	50	45	40	36	30	30~53	730×330×320	32	37
BL(T)2-7	0.75	1			63	61	57	52	47	41	35	35~63	730×330×320	32	37
BL(T)2-9	1.1	1.5			80	78	73	67	61	54	45	45~80	790×330×320	35	40
BL(T)2-11	1.1	1.5			98	95	89	82	73	64	54	54~98	790×330×320	36	41
BL(T)2-13	1.5	2			116	114	106	98	89	78	65	65~116	840×330×320	40	45
BL(T)2-15	1.5	2			134	130	123	112	100	90	73	73~134	880×330×320	41	46
BL(T)2-18	2.2	3			161	157	148	136	121	108	91	91~161	930×330×320	46	51
BL(T)2-22	2.2	3			197	192	180	165	148	130	110	110~197	1030×330×440	49	54
BL(T)2-26	3	4			232	228	214	198	179	158	130	130~232	1100×330×440	58	62

Model	Power		Caliber	Q (m³/h)	1.5	2	3	4	5	6	Head Range (m)	Packing Dim. (L×W×H) mm	G.W.(kg)	
	kW	HP											BL	BLT
BL(T)4-2	0.37	0.5	DN25 (1 1/4')	H (m)	19	18	17	15	13	10	10~19	595x285x360	28	33
BL(T)4-3	0.55	0.75			28	27	26	24	20	18	18~28	625x285x360	30	35
BL(T)4-4	0.75	1			38	36	34	32	27	24	24~38	725x285x375	34	39
BL(T)4-5	1.1	1.5			47	45	43	40	34	31	31~47	725x285x375	36	41
BL(T)4-6	1.1	1.5			56	54	52	48	41	37	37~56	785x285x375	37	42
BL(T)4-7	1.5	2			66	63	61	56	48	43	43~66	845x285x385	40	46
BL(T)4-8	1.5	2			74	72	70	64	55	50	50~74	845x285x385	41	47
BL(T)4-10	2.2	3			96	90	87	81	71	62	62~96	885x285x385	45	51
BL(T)4-12	2.2	3			114	108	104	95	85	75	75~114	935x285x385	47	52
BL(T)4-14	3	4			136	126	122	112	101	89	89~136	1045x285x385	55	60
BL(T)4-16	3	4			152	144	140	129	115	101	101~152	1135x290x385	57	62
BL(T)4-19	4	5.5			183	171	168	153	137	122	122~183	1205x315x390	66	71
BL(T)4-22	4	5.5			211	200	192	178	160	138	138~211	1285x315x390	68	74

Vertical Multi-Stage Centrifugal Pumps

Performance Data

Model	Power		Caliber	Q (m³/h)	5	6	7	8	9	10	11	Head Range (m)	Packing Dim. (L×W×H) mm	G.W.(kg)	
	kW	HP												BL	BLT
BL(T)8-2	0.75	1	DN40 (1.5')	H (m)	20	19.5	19	18	17	16	14	14~20	795x325x400	43	50
BL(T)8-3	1.1	1.5			30	29.5	28.5	27	25	24	21	21~30	795x325x400	45	52
BL(T)8-4	1.5	2			41	39.5	38	36	34	32	28	28~41	865x325x400	50	57
BL(T)8-5	2.2	3			52	50	48	45	42	40	36	36~52	865x325x400	54	61
BL(T)8-6	2.2	3			62	60	57	54	51	48	43	43~62	915x325x415	55	62
BL(T)8-8	3	4			83	80	77	73	69	65	58	58~83	1005x325x405	65	72
BL(T)8-10	4	5.5			104	100	97	92	87	81	73	73~104	1115x350x440	76	82
BL(T)8-11	4	5.5			114	110	106	101	95	86	80	80~114	1115x350x440	77	84
BL(T)8-12	4	5.5			124	120	116	111	104	92	87	87~124	1265x400x490	96	103
BL(T)8-14	5.5	7.5			145	141	136	130	122	113	102	102~145	1355x400x490	98	106
BL(T)8-16	5.5	7.5			166	161	156	148	139	130	118	118~166	1415x400x490	101	109
BL(T)8-18	7.5	10			187	182	175	167	157	146	134	134~187	1485x400x490	108	116
BL(T)8-20	7.5	10			208	202	195	186	175	163	150	150~208	1535x400x490	111	118

Model	Power		Caliber	Q (m³/h)	7	8	10	12	14	15	Head Range (m)	Packing Dim. (L×W×H) mm	G.W.(kg)	
	kW	HP											BL	BLT
BL(T)12-2	1.5	2	DN50 (2')	H (m)	23.5	23	22	20	17	15	15~23.5	775x325x340	47	56
BL(T)12-3	2.2	3			35.5	35	33	30	26	23	23~35.5	775x325x340	51	60
BL(T)12-4	3	4			47	46	44	40	34	31	31~47	835x325x415	59	68
BL(T)12-5	3	4			59.5	58	55	50	43	39	39~59.5	885x325x415	60	69
BL(T)12-6	4	5.5			71.5	70	66	60	52	47	47~71.5	945x325x415	69	78
BL(T)12-7	5.5	7.5			83.5	82	77	70	61	55	55~83.5	1175x400x490	90	100
BL(T)12-8	5.5	7.5			95.5	94	88	80	70	63	63~95.5	1175x400x490	92	101
BL(T)12-9	5.5	7.5			108	106	100	91	79	71	71~108	1175x400x490	93	102
BL(T)12-10	7.5	10			120	118	111	101	88	80	80~120	1265x400x490	99	108
BL(T)12-12	7.5	10			143.5	141	133	121	106	96	96~143.5	1265x400x490	101	110
BL(T)12-14	11	15			168	165	155	141	124	112	112~168	1425x520x560	178	187
BL(T)12-16	11	15			192.5	189	178	162	142	128	128~192.5	1515x520x560	181	190
BL(T)12-18	11	15			217	213	202	183	160	145	145~217	1605x520x560	184	193

BW/BWJ

Horizontal Multi-Stage Centrifugal Pumps



BW

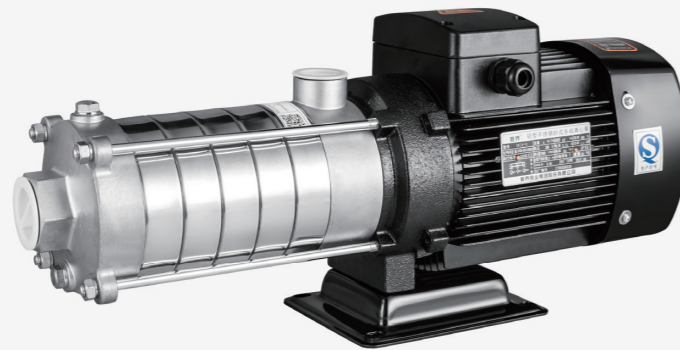

BWJ

Horizontal Multi-Stage Centrifugal Pumps

Performance Data

Model	Power		Q (m³/h)	0.5	1	1.5	2	2.5	3.0	3.5	Head Range (m)	Packing Dim. (L×W×H) mm	G.W. (kg)
	kW	HP											
BW2-2	0.37	0.5	H (m)	19	18	16.5	15	13	10	7.5	7.5 ~ 19	450×228×305	11
BW2-3	0.37	0.5		28	26.5	24.5	22	19	15.5	12	12 ~ 28	450×228×305	12
BW2-4	0.55	0.75		36	34.5	33	29	25	20.5	16	16 ~ 36	450×228×305	13
BW2-5	0.55	0.75		45.5	43	40	36	31.5	26.5	20.5	20.5 ~ 45.5	450×228×305	14
BW2-6	0.75	1		53.5	51	48	44	39	32	24	24 ~ 53.5	450×228×305	16

Model	Power		Q (m³/h)	1	2	3	4	5	6	7	Head Range (m)	Packing Dim. (L×W×H) mm	G.W. (kg)
	kW	HP											
BW4-2	0.37	0.5	H (m)	19	18	17	15	12.5	10	8	8 ~ 19	450×228×305	12
BW4-3	0.55	0.75		28	27	26	23.5	20.5	17	13	13 ~ 28	450×228×305	13
BW4-4	0.75	1		37.5	36	34	31	27	23	19	19 ~ 37.5	450×228×305	16

Model	Power		Q (m³/h)	5	6	7	8	9	10	11	Head Range (m)	Packing Dim. (L×W×H) mm	G.W. (kg)
	kW	HP											
BW8-2	0.75	1	H (m)	20	19.5	19	18	17	15.5	14	14 ~ 20	635×265×330	15
BW8-3	1.1	1.5		29.5	29	28	27	25	23	21	21 ~ 29.5	635×265×330	21
BW8-4	1.5	2		39	38	37	35	33	30.5	27.5	27.5 ~ 39	635×265×330	25
BW8-5	2.2	3		51	49.5	47.5	45	42.5	39.5	36	36 ~ 51	635×265×330	26

Model	Power		Q (m³/h)	8	10	12	14	16	18	20	22	Head Range (m)	Packing Dim. (L×W×H) mm	G.W. (kg)
	kW	HP												
BW16-2	2.2	3	H (m)	26	25	24	23	21.7	20	18	15.5	15.5 ~ 26	635×265×330	28
BW16-3	3	4		40	39	38	36	34	31.5	29	25	25 ~ 40	635×265×330	35

Application Limits

- Temperature range of medium: Normal type 0 ~ +68°C , hot water type 0 ~ +120°C
- Maximum ambient temperature: +40 °C
- Maximum working pressure: 1MPa
- When pumping liquids with a density and/or viscosity higher than that of water,use motors with correspondingly higher outputs,if required.
- pH: 5 to 9

Horizontal Multi-Stage Centrifugal Pumps

Performance Data

Model	Power		Q (m³/h)	0.5	1.0	1.5	2.0	2.5	3.0	3.5	Head Range (m)	Packing Dim. (L×W×H) mm	G.W. (kg)
	kW	HP											
BWJ2-2	0.37	0.5	H (m)	19	18	16.5	15	13	10	7.5	7.5 ~ 19	390 × 288 × 305	12
BWJ2-3	0.37	0.5		28	26.5	24.5	22	19	15.5	12	12 ~ 28	390 × 288 × 305	12
BWJ2-4	0.55	0.75		36	34.5	33	29	25	20.5	16	16 ~ 36	390 × 288 × 305	13
BWJ2-5	0.55	0.75		45.5	43	40	36	31.5	26.5	20.5	20.5 ~ 45.5	390 × 288 × 305	13
BWJ2-6	0.75	1		53.5	51	48	44	39	32	24	24 ~ 53.5	550 × 288 × 305	17

Model	Power		Q (m³/h)	1	2	3	4	5	6	7	Head Range (m)	Packing Dim. (L×W×H) mm	G.W. (kg)
	kW	HP											
BWJ4-2	0.37	0.5	H (m)	19	18	17	15	12.5	10	8	8 ~ 19	390 × 288 × 305	12
BWJ4-3	0.55	0.75		28	27	26	23.5	20.5	17	13	13 ~ 28	390 × 288 × 305	13
BWJ4-4	0.75	1		37.5	36	34	31	27	23	19	19 ~ 37.5	550 × 288 × 305	17
BWJ4-5	1.1	1.5		47	45	42.5	39	34	29	23	23 ~ 47	550 × 288 × 305	20
BWJ4-6	1.1	1.5		56	54	51	47	41.5	35.5	28	28 ~ 56	550 × 288 × 305	21

Model	Power		Q (m³/h)	5	6	7	8	9	10	11	Head Range (m)	Packing Dim. (L×W×H) mm	G.W. (kg)
	kW	HP											
BWJ8-2	0.75	1	H (m)	20	19.5	19	18	17	15.5	14	14 ~ 20	635 × 265 × 330	19
BWJ8-3	1.1	1.5		29.5	29	28	27	25	23	21	21 ~ 29.5	635 × 265 × 330	22
BWJ8-4	1.5	2		39	38	37	35	33	30.5	27.5	27.5 ~ 39	635 × 265 × 330	26
BWJ8-5	2.2	3		51	49.5	47.5	45	42.5	39.5	36	36 ~ 51	635 × 265 × 330	29

Model	Power		Q (m³/h)	8	10	12	14	16	18	20	22	Head Range (m)	Packing Dim. (L×W×H) mm	G.W. (kg)
	kW	HP												
BWJ16-2	2.2	3	H (m)	26	25	24	23	21.7	20	18	15.5	15.5 ~ 26	635 × 265 × 330	27
BWJ16-3	3	4		40	39	38	36	34	31.5	29	25	25 ~ 40	635 × 265 × 330	31

BW1

Light horizontal multi-stage centrifugal stainless steel pump



Application Limits

- Thin, clean, non-combustible, and non-explosive liquid containing no solid particle or fiber
- Applicable to deliver tap water, alkaline mineral water, softened water or mildly-corrosive medium
- The use of a large-power motor must be considered when the density or viscosity of the medium delivered is higher than that of water.
- Medium temperature: 0°C -68°C for normal temperature type; 0°C -120°C for hot water type
- Ambient temperature: -15°C -+40°C ; maximum operating pressure: 1.0MPa

Performance Data

Model	Rated flow (m³/h)	Flow range (m³/h)	Maximum pressure (bar)	Motor power (kW)	Maximum efficiency (%)	Temperature range (°C)	Inlet	Outlet
BW1 1	1	0.4-2.4	5.1	0.25-0.37	28	0°C -68°C for normal temperature type; 0°C -120°C for hot water type	G1	G1
BW1 2	2	0.8-4	5.6	0.25-0.75	39		G1	G1
BW1 3	3	0.8-4	5.6	0.25-0.75	49		G1	G1
BW1 4	4	1-6	5.6	0.37-1.3	52		G1 1/4	G1
BW1 5	5	1-6	5.6	0.37-1.3	56		G1 1/4	G1

BWE/BLE

Fully Integrated Pump Variable Frequency Pump CATALOGUE FOR 50Hz



BLTE



BWE



BWJE

Application Limits

- ◎ Residential water: High-rise building roof pressurization, apartment, villa and so on.
- ◎ Public places: schools, restaurants, stations, hospitals, gymnasiums, etc.
- ◎ Commercial buildings: hotels, office buildings, department stores, etc.
- ◎ Irrigation: farms, orchards, parks, etc.
- ◎ Industry: manufacturing, food manufacturing, industrial water and other constant pressure water supply sites.

Fully Integrated Pump Variable Frequency Pump

Performance Data

No	Model	Input voltage	Constant pressure value set (MPa)	The factory set constant value (rated pressure) MPa	Inlet diameter	Outlet diameter	Single pump power	The highest lift (zero flow) m	Rated flow m ³ /h	Pressure tank volume L
A01	BWE2-6	1ΦAC220V	0.05-0.44	0.44	G1	G1	0.75	56	2	3
A02	BWE4-4	1ΦAC220V	0.05-0.32	0.32	G1 ¹ / ₄	G1	0.75	38	4	3
A03	BWE8-2	1ΦAC220V	0.05-0.18	0.18	G2	G2	0.75	22	8	5
A04	BWE8-3	1ΦAC220V	0.05-0.26	0.26	G2	G2	1.1	32	8	5
A05	BWE8-4	1ΦAC220V	0.05-0.36	0.36	G2	G2	1.5	43	8	5
A06	BWE8-5	1ΦAC220V	0.05-0.44	0.44	G2	G2	2.2	54	8	5
A07	BWE16-2	1ΦAC220V	0.05-0.23	0.23	G2	G2	2.2	27	16	5
A08	BWJE2-6	1ΦAC220V	0.05-0.44	0.44	G1	G1	0.75	56	2	3
A09	BWJE4-4	1ΦAC220V	0.05-0.32	0.32	G1 ¹ / ₄	G1	0.75	38	4	3
A10	BWJE4-5	1ΦAC220V	0.05-0.40	0.40	G1 ¹ / ₄	G1	1.1	47	4	3
A11	BWJE4-6	1ΦAC220V	0.05-0.48	0.48	G1 ¹ / ₄	G1	1.1	57	4	3
A12	BWJE8-2	1ΦAC220V	0.05-0.18	0.18	G1 ¹ / ₂	G1 ¹ / ₄	0.75	22	8	5
A13	BWJE8-3	1ΦAC220V	0.05-0.26	0.26	G1 ¹ / ₂	G1 ¹ / ₄	1.1	32	8	5
A14	BWJE8-4	1ΦAC220V	0.05-0.36	0.36	G1 ¹ / ₂	G1 ¹ / ₄	1.5	43	8	5
A15	BWJE8-5	1ΦAC220V	0.05-0.44	0.44	G1 ¹ / ₂	G1 ¹ / ₄	2.2	54	8	5
A16	BWJE16-2	1ΦAC220V	0.05-0.23	0.23	G1 ¹ / ₂	G1 ¹ / ₄	2.2	27	16	5
B01	BL(T)E2-6	1ΦAC220V	0.05-0.44	0.44	R ₂ 1 ¹ / ₄	R ₂ 1 ¹ / ₄	0.75	58	2	3
B02	BL(T)E2-7	1ΦAC220V	0.05-0.54	0.54	R ₂ 1 ¹ / ₄	R ₂ 1 ¹ / ₄	0.75	68	2	3
B03	BL(T)E2-9	1ΦAC220V	0.05-0.69	0.69	R ₂ 1 ¹ / ₄	R ₂ 1 ¹ / ₄	1.1	87	2	5
B04	BL(T)E2-11	1ΦAC220V	0.05-0.84	0.84	R ₂ 1 ¹ / ₄	R ₂ 1 ¹ / ₄	1.1	106	2	5
B05	BL(T)E2-13	1ΦAC220V	0.05-1.0	1.00	R ₂ 1 ¹ / ₄	R ₂ 1 ¹ / ₄	1.5	124	2	5
B06	BL(T)E2-15	1ΦAC220V	0.05-1.14	1.14	R ₂ 1 ¹ / ₄	R ₂ 1 ¹ / ₄	1.5	138	2	5
B07	BL(T)E4-4	1ΦAC220V	0.05-0.32	0.32	R ₂ 1 ¹ / ₄	R ₂ 1 ¹ / ₄	0.75	38	4	3
B08	BL(T)E4-5	1ΦAC220V	0.05-0.40	0.40	R ₂ 1 ¹ / ₄	R ₂ 1 ¹ / ₄	1.1	47	4	3
B09	BL(T)E4-6	1ΦAC220V	0.05-0.48	0.48	R ₂ 1 ¹ / ₄	R ₂ 1 ¹ / ₄	1.1	58	4	3
B10	BL(T)E4-7	1ΦAC220V	0.05-0.55	0.55	R ₂ 1 ¹ / ₄	R ₂ 1 ¹ / ₄	1.5	69	4	3
B11	BL(T)E4-8	1ΦAC220V	0.05-0.63	0.63	R ₂ 1 ¹ / ₄	R ₂ 1 ¹ / ₄	1.5	78	4	5
B12	BL(T)E4-10	1ΦAC220V	0.05-0.79	0.79	R ₂ 1 ¹ / ₄	R ₂ 1 ¹ / ₄	2.2	96	4	5
B13	BL(T)E4-12	1ΦAC220V	0.05-0.95	0.95	R ₂ 1 ¹ / ₄	R ₂ 1 ¹ / ₄	2.2	117	4	5
B14	BL(T)E8-2	1ΦAC220V	0.05-0.18	0.18	DN40	DN40	0.75	22	8	5
B15	BL(T)E8-3	1ΦAC220V	0.05-0.26	0.26	DN40	DN40	1.1	32	8	5
B16	BL(T)E8-4	1ΦAC220V	0.05-0.36	0.36	DN40	DN40	1.5	42	8	5
B17	BL(T)E8-5	1ΦAC220V	0.05-0.46	0.46	DN40	DN40	2.2	53	8	5
B18	BL(T)E8-6	1ΦAC220V	0.05-0.55	0.55	DN40	DN40	2.2	62	8	5
B19	BL(T)E12-2	1ΦAC220V	0.05-0.20	0.20	DN50	DN50	1.5	26	12	5
B20	BL(T)E12-3	1ΦAC220V	0.05-0.31	0.31	DN50	DN50	2.2	38	12	5
B21	BL(T)E16-2	1ΦAC220V	0.05-0.23	0.23	DN50	DN50	2.2	28	16	5
B22	BL(T)E20-2	1ΦAC220V	0.05-0.23	0.23	DN50	DN50	2.2	30	20	10

Overall Dimensions of Variable-frequency Pump

Performance Data

Model	L	L1	B	H	H1	N.W (kg)	G.W (kg)	Sketch map
BWE2-6	419	165	165	540	111	19	21.5	1
BWE4-4	426	165	165	540	111	19	21.5	1
BWE8-2	539	283	228	610	118	18.5	22.3	1
BWE8-3	539	283	228	610	118	24.5	28.3	1
BWE8-4	590	283	228	610	118	28.5	32.3	1
BWE8-5	590	283	228	610	118	32.5	36.3	1
BWE16-2	590	283	228	610	118	31.5	35.3	1

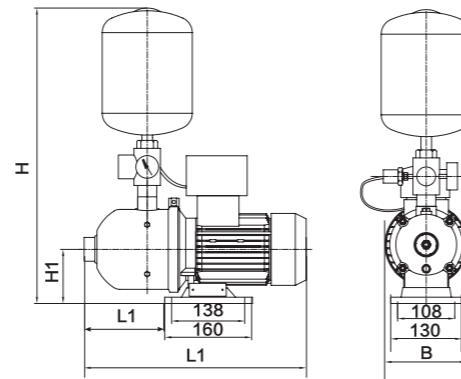

Figure 1

Model	L	L1	B	H	H1	N.W (kg)	G.W (kg)	Sketch map
BWJE2-6	414	151	220	540	111	20.3	22.8	2
BWJE4-4	413	151	220	540	111	19	21.5	2
BWJE4-5	440	178	220	540	111	22.3	25	2
BWJE4-6	467	232	220	540	111	23	25.5	2
BWJE8-2	376	111	220	600	114	22.9	26.7	2
BWJE8-3	406	141	220	600	114	25	28.8	2
BWJE8-4	503	171	220	600	118	29.5	33.3	2
BWJE8-5	533	201	220	600	118	32.1	35.9	2
BWJE16-2	467	125	220	600	118	34.1	37.9	2

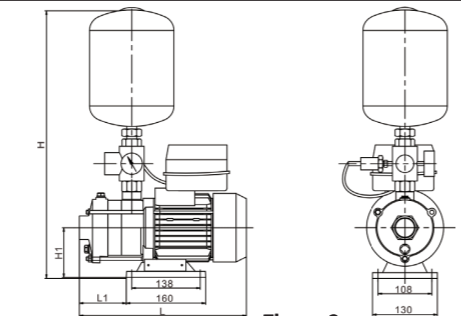

Figure 2

Model	L	L1	L2	B	B1	H	H1	N.W(kg)		G.W(kg)		Sketch map
								BL	BLT	BL	BLT	
BL(T)E2-6	610	550	100	320	280	625	105	37	43	52	58	3
BL(T)E2-7	610	550	100	320	280	643	105	37	43	52	58	3
BL(T)E2-9	610	550	100	320	280	679	105	40	46	57	63	3
BL(T)E2-11	610	550	100	320	280	715	105	41	47	58	64	3
BL(T)E2-13	610	550	100	320	280	809	105	44	51	63	70	3
BL(T)E2-15	610	550	100	320	280	845	105	45	51	64	70	3
BL(T)E4-4	610	550	100	320	280	625	105	37	44	52	59	3
BL(T)E4-5	610	550	100	320	280	652	105	39	46	54	61	3
BL(T)E4-6	610	550	100	320	280	679	105	40	47	57	64	3
BL(T)E4-7	610	550	100	320	280	764	105	43	51	61	69	3
BL(T)E4-8	610	550	100	320	280	791	105	44	51	62	69	3
BL(T)E4-10	610	550	100	320	280	845	105	48	55	66	73	3
BL(T)E4-12	610	550	100	320	280	879	105	49	57	69	77	3

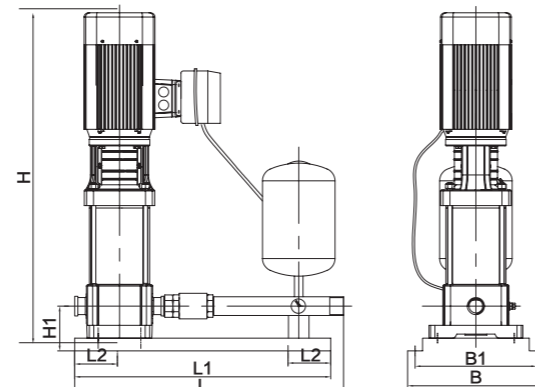

Figure 3

Model	L	L1	L2	B	B1	H	H1	N.W(kg)		G.W(kg)		Sketch map
								BL	BLT	BL	BLT	
BL(T)E8-2	750	700	100	360	320	650	110	53	63	72	82	4
BL(T)E8-3	750	700	100	360	320	680	110	55	65	74	84	4
BL(T)E8-4	750	700	100	360	320	760	110	59	69	80	90	4
BL(T)E8-5	750	700	100	360	320	790	110	63	73	84	94	4
BL(T)E8-6	750	700	100	360	320	820	110	64	74	85	95	4
BL(T)E12-2	800	750	100	360	320	713	120	59	69	80	90	4
BL(T)E12-3	800	750	100	360	320	745	120	62	72	83	93	4
BL(T)E16-2	800	750	100	360	320	740	120	62	73	83	94	4
BL(T)E20-2	800	750	100	360	320	740	120	64	74	85	95	4

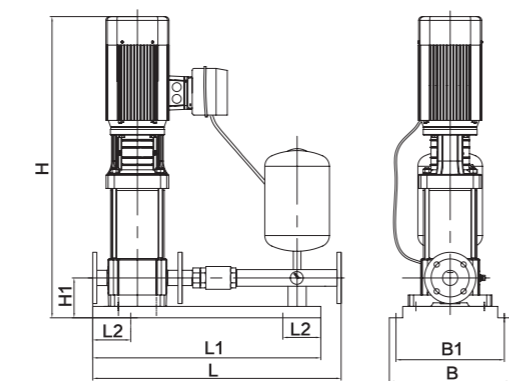

Figure 4

Fully Integrated Pump Variable Frequency Pump

Packing Sizes & Weight

Model	Dim.(mm) LxWxH	Model	Dim.(mm) LxWxH
BWE2-6	520 × 260 × 590	BL(T)E2-13	820 × 350 × 990
BWE4-4	520 × 260 × 590	BL(T)E2-15	820 × 350 × 990
BWE8-2	660 × 290 × 700	BL(T)E4-4	820 × 350 × 790
BWE8-3	660 × 290 × 700	BL(T)E4-5	820 × 350 × 790
BWE8-4	660 × 290 × 700	BL(T)E4-6	820 × 350 × 860
BWE8-5	660 × 290 × 700	BL(T)E4-7	820 × 350 × 990
BWE16-2	660 × 290 × 700	BL(T)E4-8	820 × 350 × 990
BWJE2-6	520 × 260 × 590	BL(T)E4-10	820 × 350 × 990
BWJE4-4	520 × 260 × 590	BL(T)E4-12	820 × 350 × 1040
BWJE4-5	580 × 260 × 570	BL(T)E8-2	920 × 380 × 840
BWJE4-6	580 × 260 × 570	BL(T)E8-3	920 × 380 × 840
BWJE8-2	660 × 290 × 700	BL(T)E8-4	920 × 380 × 990
BWJE8-3	660 × 290 × 700	BL(T)E8-5	920 × 380 × 990
BWJE8-4	660 × 290 × 700	BL(T)E8-6	920 × 380 × 990
BWJE8-5	660 × 290 × 700	BL(T)E12-2	920 × 380 × 990
BWJE16-2	660 × 290 × 700	BL(T)E12-3	920 × 380 × 990
BL(T)E2-6	820 × 350 × 790	BL(T)E16-2	920 × 380 × 990
BL(T)E2-7	820 × 350 × 790	BL(T)E20-2	920 × 380 × 990
BL(T)E2-9	820 × 350 × 860	-	-
BL(T)E2-11	820 × 350 × 860	-	-

PLD

PLD Economical Vertical Multistage Pump



Conditions

- ◎ The temperature of the medium does not exceed +60°C ;
- ◎ The ambient temperature does not exceed +40°C ;
- ◎ The PH value of the medium is between 6.5 and 8.5, the volume ratio of solid impurities in the medium is ≤ 0.1%, and the particle size is ≤ 0.2mm.
- ◎ The maximum working pressure is 15 bar;
- ◎ The highest altitude is 1000m;

PLD Economical Vertical Multistage Pump

Performance Data

Model		Power		Q(m³/h)	0	1	2	3	4
Single-Phase	Three phase	kW	HP	Q(L/min)	0	16.7	33.3	50	66.7
PLD2-6	PL2-6	1.1	1.5	H (m)	69	65	53	45	18
PLD2-7	PL2-7	1.1	1.5		82	75	65.5	52	25
PLD2-8	PL2-8	1.5	2		94	87	73	59	28
PLD2-9	PL2-9	1.5	2		105	98	84	67	35
PLD2-11	PL2-11	1.8	2.5		130	119	102	82	37
-	PL2-13	2.2	3		153	142	122	97	39

Model	Dim.(mm) LxWxH	N.W (kg)	G.W (kg)
PL2-6	595 × 240 × 270	21	21.5
PLD2-6	595 × 240 × 270	22	22.5
PL2-7	620 × 240 × 270	21.5	22
PLD2-7	620 × 240 × 270	22.5	23
PL2-8	645 × 240 × 270	23	23.5
PLD2-8	645 × 240 × 270	24.5	25
PL2-9	670 × 240 × 270	23.5	24
PLD2-9	670 × 240 × 270	25	25.5
PL2-11	715 × 240 × 270	25.5	26
PLD2-11	715 × 240 × 270	27	27.5
PL2-13	765 × 240 × 270	28	28.5

Model		Power		Q(m³/h)	0	1	2	3	4	5	6
Single-Phase	Three phase	kW	HP	Q(L/min)	0	16.7	33.3	50	66.7	83.3	100
PLD4-4	PL4-4	1.1	1.5	H (m)	47	46	45	41	39	28	20
PLD4-5	PL4-5	1.5	2		61	58	57	55	48	39	29
PLD4-6	PL4-6	1.5	2		74	72	69	66	58	47	36
PLD4-7	PL4-7	1.8	2.5		86	83	81	77	69	57	43
-	PL4-8	2.2	3		98	95	92	86	77	63	47
-	PL4-10	2.2	3		116	114	110	102	96	73	57

Model	Dim.(mm) LxWxH	N.W (kg)	G.W (kg)
PL4-4	545 × 240 × 270	20	20.5
PLD4-4	545 × 240 × 270	21	21.5
PL4-5	570 × 240 × 270	22	22.5
PLD4-5	570 × 240 × 270	23	23.5
PL4-6	595 × 240 × 270	22	22.5
PLD4-6	595 × 240 × 270	23.5	24
PL4-7	620 × 240 × 270	24	24.5
PLD4-7	620 × 240 × 270	25.5	26
PL4-8	645 × 240 × 270	26	26.5
PL4-10	645 × 240 × 270	26.5	27
PL2-13	765 × 240 × 270	28	28.5

APM

Application Limits

- Liquid temperature: 2°C ~ 110°C
- Maximum ambient temperature +40°C
- Maximum system pressure 10bar
- Protection level: IP42
- Mains connection: 220V~240V 50Hz~60Hz
- Insulation class: F
- Pumped liquid characteristics: clean, free from solids and mineral oils, non-toxic, chemically neutral, close to the characteristics of water
- Installation: the motor shaft must be kept in horizontal direction
- pH: 6.5 to 8.5

Advantages & Features

- “A” Rated energy efficiency–lowest power consumption
- Permanent magnet motor–intelligent frequency conversion control
- Proportional pressure mode(PP)
- Constant pressure mode(CP)
- Constant speed mode(S)
- AUTO mode
- Night–setback mode
- Actual power display
- Low noise, no leakage



EEI ≤ 0.20



Performance Data

Model	Input Power P ₁ (W)	Current(A) 220V 50Hz/60Hz	Pipe Distance (mm)	Max. head (m)	Whole lift (m)	Max. flow (m ³ /h)	Inter Box		Outer Box			20" Loading Qty (pcs)
							G.W. (kg)	Dim. (L×W×H)	PCS/ CTN	Dim (L×W×H)	G.W. (kg)	
APM20-4-130	22	0.17	130	4	0~4	2.5	2.1	200x145x175	4	420x310x195	13	5760
APM20-6-130	45	0.35	130	6	0~6	3	2.1	200x145x175	4	420x310x195	13	5760
APM25-4-130	22	0.17	130	4	0~4	2.5	2.4	200x145x175	4	420x310x195	14.5	5760
APM25-6-130	45	0.35	130	6	0~6	3	2.4	200x145x175	4	420x310x195	14.5	5760
APM25-4-180	22	0.17	180	4	0~4	2.5	2.5	200x145x175	4	420x310x195	15.5	5760
APM25-6-180	45	0.35	180	6	0~6	3	2.5	200x145x175	4	420x310x195	15.5	5760
APM32-4-180	22	0.17	180	4	0~4	2.5	2.7	200x145x175	4	420x310x195	16.5	5760
APM32-6-180	45	0.35	180	6	0~6	3	2.7	200x145x175	4	420x310x195	16.5	5760

APF

Application Limits

- Liquid temperature: 2°C ~ 110°C
- Maximum ambient temperature +40°C
- Maximum system pressure 10bar
- Protection level: IP42/IP44
- Mains connection: 220V ~ 240V; 50Hz
- Insulation class: F
- Pumped liquid characteristics: clean, free from solids and mineral oils, non-toxic, chemically neutral, close to the characteristics of water
- Installation: the motor shaft must be kept in horizontal direction

Features

- “A” Rated energy efficiency–lowest power consumption
- Permanent magnet motor–intelligent frequency conversion control
- Proportional pressure mode
- Constant speed mode
- Low noise, no leakage



EEI ≤ 0.20

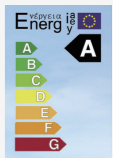

Performance Data

Model	Pipe Distance (mm)	Electrical Data			Max.head (m)	Max. flow (m ³ /h)
		Voltage	P1(W)	In (A)		
APF20-4-130	130	220v-50Hz	22	0.17	4	2.5
APF20-6-130	130		45	0.35	6	3.0
APF25-4-130	130		22	0.17	4	2.5
APF25-6-130	130		45	0.35	6	3.0
APF25-4-180	180		22	0.17	4	2.5
APF25-6-180	180		45	0.35	6	3.0
APF25-8-180	180		88	0.72	8	8.0
APF32-4-180	180		22	0.17	4	2.5
APF32-6-180	180		45	0.35	6	3.0
APF32-8-180	180		88	0.72	8	8.0

BPS

Application Limits

- Liquid temperature: +2°C ~ +95°C
- Maximum ambient temperature +40°C
- Maximum system pressure 10bar
- Protection level: IP44
- Mains connection: 220V/50Hz
- Insulation class: H
- Pumped liquid characteristics: clean, free from solids and mineral oils, non-toxic, chemically neutral, close to the characteristics of water
- Installation: the motor shaft must be kept in horizontal direction
- pH: 6.5 to 8.5

Advantages & Features

- 3-speed adjustment
- Low noise
- No leakage
- Automatic Exhaust
- Various pump body structures applied to various types of installation

Performance Data

Model	Speed	Input Power P1(W)	Current (A)	Capacitor μF/450V	Pipe Distance (mm)	Max. head (m)	Whole lift (m)	Max. flow (m³/h)	Inter Box		Outer Box		20" Loading Qty (pcs)
									G.W. (kg)	Dim. (L x W x H)	PCS/CTN	Dim. (L x W x H)	
BPS15-5A	3	95	0.41	2.5	-	5	0-5	2	2	150x130x140	320x280x300	16.5	6664
	2	75	0.33	2.5	-	5	0-5		2	150x130x140	320x280x300	16.5	6664
	1	50	0.23	2.5	-	5	0-5		2	150x130x140	320x280x300	16.5	6664
BPS15-6A	3	105	0.43	2.5	-	6	0-6		2	150x130x140	320x280x300	16.5	6664
	2	80	0.36	2.5	-	6	0-6		2	150x130x140	320x280x300	16.5	6664
	1	55	0.26	2.5	-	6	0-6		2	150x130x140	320x280x300	16.5	6664
BPS15-7A	3	130	0.58	3	-	6.7	0-7		2	150x130x140	320x280x300	16.5	6664
	2	115	0.53	3	-	6.7	0-7		2	150x130x140	320x280x300	16.5	6664
	1	70	0.38	3	-	6.7	0-7		2	150x130x140	320x280x300	16.5	6664
BPS15-5B	3	95	0.41	2.5	130	5	0-5		2	155x130x150	330x280x320	16.5	5712
	2	75	0.33	2.5	130	5	0-5		2	155x130x150	330x280x320	16.5	5712
	1	50	0.23	2.5	130	5	0-5		2	155x130x150	330x280x320	16.5	5712
BPS15-6B	3	105	0.43	2.5	130	6	0-6	2	155x130x150	330x280x320	16.5	5712	
	2	80	0.36	2.5	130	6	0-6	2	155x130x150	330x280x320	16.5	5712	
	1	55	0.26	2.5	130	6	0-6	2	155x130x150	330x280x320	16.5	5712	
BPS15-7B	3	130	0.58	3	130	6.7	0-7	2	155x130x150	330x280x320	16.5	5712	
	2	115	0.53	3	130	6.7	0-7	2	155x130x150	330x280x320	16.5	5712	
	1	80	0.38	3	130	6.7	0-7	2	155x130x150	330x280x320	16.5	5712	
BPS15-5C	3	95	0.41	2.5	-	5	0-5	2	155x130x150	330x280x320	16.5	5712	
	2	75	0.33	2.5	-	5	0-5	2	155x130x150	330x280x320	16.5	5712	
	1	50	0.23	2.5	-	5	0-5	2	155x130x150	330x280x320	16.5	5712	
BPS15-6C	3	105	0.43	2.5	-	6	0-6	2	155x130x150	330x280x320	16.5	5712	
	2	80	0.36	2.5	-	6	0-6	2	155x130x150	330x280x320	16.5	5712	
	1	55	0.26	2.5	-	6	0-6	2	155x130x150	330x280x320	16.5	5712	
BPS15-5D	3	95	0.41	2.5	-	5	0-5	2.2	170x120x180	500x360x200	18.5	5280	
	2	75	0.33	2.5	-	5	0-5	2.2	170x120x180	500x360x200	18.5	5280	
	1	50	0.23	2.5	-	5	0-5	2.2	170x120x180	500x360x200	18.5	5280	
BPS15-6D	3	105	0.43	2.5	-	6	0-6	2.2	170x120x180	500x360x200	18.5	5280	
	2	80	0.36	2.5	-	6	0-6	2.2	170x120x180	500x360x200	18.5	5280	
	1	55	0.26	2.5	-	6	0-6	2.2	170x120x180	500x360x200	18.5	5280	
BPS15-5E	3	95	0.41	2.5	-	5	0-5	2.2	170x120x180	500x360x200	18.5	5280	
	2	75	0.33	2.5	-	5	0-5	2.2	170x120x180	500x360x200	18.5	5280	
	1	50	0.23	2.5	-	5	0-5	2.2	170x120x180	500x360x200	18.5	5280	
BPS15-6E	3	105	0.43	2.5	-	6	0-6	2.2	170x120x180	500x360x200	18.5	5280	
	2	80	0.36	2.5	-	6	0-6	2.2	170x120x180	500x360x200	18.5	5280	
	1	55	0.26	2.5	-	6	0-6	2.2	170x120x180	500x360x200	18.5	5280	

XPS

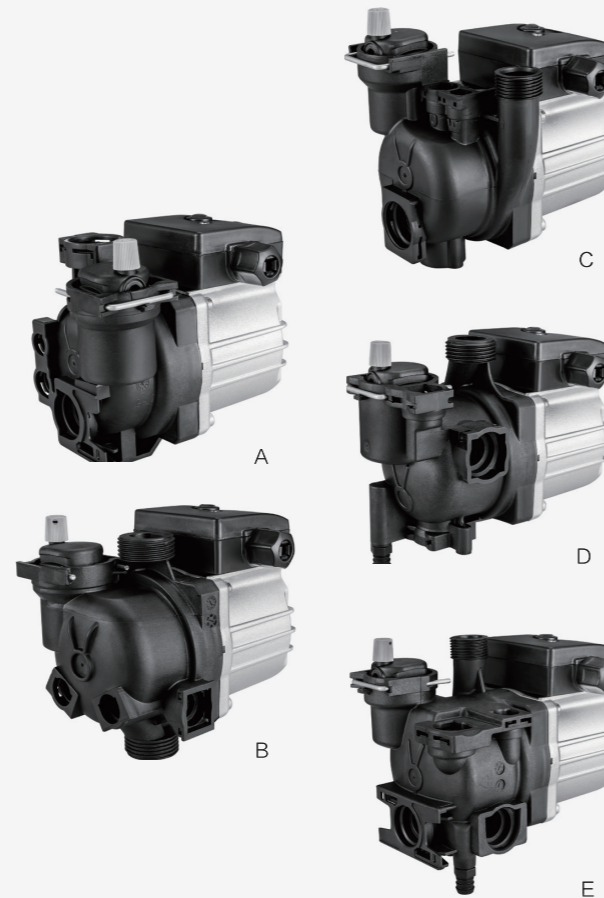

XPS



XPS

Application Limits

- Liquid temperature: +2°C ~ +110°C
- Maximum ambient temperature +40°C
- Maximum system pressure 10bar
- Protection level: IP44
- Mains connection: 220V/50Hz
- Insulation class: H
- Pumped liquid characteristics: clean, free from solids and mineral oils, non-toxic, chemically neutral, close to the characteristics of water
- Installation: the motor shaft must be kept in horizontal direction
- pH: 6.5 to 8.5

Advantages & Features

- 3-speed adjustment
- Low noise
- No leakage

ZP/ZPS

Application Limits

- Liquid temperature: +2°C ~ +90°C
- Maximum ambient temperature +40°C
- Maximum system pressure 10bar
- Protection level: IP44
- Mains connection: 220V/50Hz、220V/60Hz、127V/60Hz
- Insulation class: H
- Pumped liquid characteristics: clean, free from solids and mineral oils, non-toxic, chemically neutral, close to the characteristics of water
- Installation: the motor shaft must be kept in horizontal direction
- pH: 6.5 to 8.5

Advantages & Features

- Automatic mode and manual mode is available
- Low noise, no leakage
- Flow switch automatic control

Performance Data

Model	Speed	Input Power P _i (W)	Current(A)		Capacitor		Pipe Distance (mm)	Max. head (m)	Whole lift (m)	Max. flow (m ³ /h)	Inter Box		Outer Box		20" Loading Qty (pcs)	
			220V 50Hz/60Hz	127V 60Hz	μ F/450V 220V 50Hz/60Hz	μ F/250V 127V/60Hz					G.W. (kg)	Dim. (L×W×H)	PCS/ CTN	Dim (L×W×H)		G.W. (kg)
ZP15-9-160	-	120	0.48	0.95	3	10	160	9	0~9	1.6	2.8	180x120x135	8	380x260x290	23	5880
	3	120	0.48	0.95	3	10	140	9	0~9	1.6	2.8	180x120x135	8	380x260x290	23	5880
ZPS15-9-140	2	85	0.38	0.66	3	10	140	9	0~9	1.6	2.8	180x120x135	8	380x260x290	23	5880
	1	60	0.26	0.45	3	10	140	9	0~9	1.6	2.8	180x120x135	8	380x260x290	23	5880
ZPS20-12-180	3	245	1.04	1.80	6	20	180	12	0~12	3.5	5	200x160x180	4	415x340x200	21	3200
	2	210	0.92	1.60	6	20	180	12	0~12	3.5	5	200x160x180	4	415x340x200	21	3200
	1	140	0.63	1.10	6	20	180	12	0~12	3.5	5	200x160x180	4	415x340x200	21	3200



ZPS



ZP

CPHB

Application Limits

- Liquid temperature: +2°C ~+75°C
- Maximum ambient temperature +40°C
- Maximum system pressure 10bar
- Protection level: IP44
- Mains connection: 220V/50Hz、220V/60Hz、127V/60Hz
- Insulation class: H
- Pumped liquid characteristics: clean, free from solids and mineral oils, non-toxic, chemically neutral, close to the characteristics of water
- Installation: the motor shaft must be kept in horizontal direction
- PH: 6.5 to 8.5

Advantages & Features

- Low noise
- No leakage
- Timing operation
- Temperature constant operation
- Timing and temperature constant operation

Performance Data

Model	Input Power P _i (W)	Current(A)			Pipe Distance (mm)	Max. head (m)	Max. flow (m ³ /h)	Inter Box		Outer Box		20" Loading Qty (pcs)	
		220V 50Hz	220V 60Hz	127V 60Hz				G.W. (kg)	Dim. (L×W×H)	PCS/ CTN	Dim (L×W×H)		G.W. (kg)
XPH15-4-130	60	0.26	/	/	130	4	2	2.6	150×140×140	8	320×300×300	21	6664
XPH15-6-130	90	0.40	0.40	0.80	130	6	2	2.6	150×140×140	8	320×300×300	21	6664
XPH20-4-130	60	0.26	/	/	130	4	2.2	2.7	150×140×140	8	320×300×300	22	6664
XPH20-6-130	90	0.40	0.40	0.80	130	6	2.2	2.7	150×140×140	8	320×300×300	22	6664
XPH25-4-130	60	0.26	/	/	130	4	3	3	150×140×140	8	320×300×300	25	6664
XPH25-6-130	90	0.40	0.40	0.80	130	6	3	3	150×140×140	8	320×300×300	25	6664
XPH25-4-180	60	0.26	/	/	180	4	3	3.2	200×130×155	8	420×280×330	26	4800
XPH25-6-180	90	0.40	0.40	0.80	180	6	3	3.2	200×130×155	8	420×280×330	26	4800
XPH32-4-180	60	0.26	/	/	180	4	3.5	3.6	200×130×150	8	420×280×330	30	4800
XPH32-6-180	90	0.40	0.40	0.80	180	6	3.5	3.6	200×130×150	8	420×280×330	30	4800

Types with "/" can be developed according to need.



XPH

CPHB

Application Limits

- Liquid temperature: +2°C ~ +100°C
- Maximum ambient temperature +40°C
- Maximum system pressure 10bar
- Protection level: IP44
- Mains connection: 220V/50Hz
- Insulation class: H
- Pumped liquid characteristics: clean, free from solids and mineral oils, non-toxic, chemically neutral, close to the characteristics of water
- Installation: the motor shaft must be kept in horizontal direction
- pH: 6.5 to 8.5

Advantages & Features

- Flange connection
- Low noise
- No leakage



CPHB

Performance Data

Model	Input Power P _i (W)	Current (A)	Capacitor		Max. head (m)	Max. flow (m ³ /h)	Whole lift (m)	G (mm)	Inter Box			Outer Box		20" Loading Qty (pcs)
			μF	Vc					G.W. (kg)	Dim. (L × W × H)	PCS/ CTN	Dim (L × W × H)	G.W. (kg)	
CPHB04-25F	90	0.26	2.5	450	4	3	0~4	25(1")	3.2	165x125x138	8	350x270x305	26	5376
CPHB04-32F	90	0.26	2.5	450	4	3	0~4	32(1 1/4")	3.2	165x125x138	8	350x270x305	26	5376
CPHB10-40F	160	0.75	4	450	5	6	0~5	40(1 1/2")	/	/	/	276x152x200	7.5	3080
CPHB10-50F	160	0.75	4	450	5	8	0~5	50(2")	/	/	/	276x152x200	7.5	3080
CPHB12-40F	260	1.21	6	450	8	7	0~8	40(1 1/2")	/	/	/	276x152x200	8	3080
CPHB12-50F	260	1.21	6	450	8	10	0~8	50(2")	/	/	/	276x152x200	8	3080

CPH

Application Limits

- Suction head up to 7m
- Liquid temperature up to +100°C
- Ambient temperature up to +40°C
- Max. Working pressure: 6bar
- Voltage fluctuation should not exceed 10% of rated value.
- pH: 6.5 to 8.5
- Mains connection: 220V/50Hz, 380V/50Hz

Advantages & Features

- Pump body: Cast iron, electrophoretic treatment
- Impeller: Cast iron, electrophoretic treatment
- Shaft: 304 stainless steel welding shaft
- Mechanical seal: SiC/Graphite/ FPM rubber
- Motor: 2 pole asynchronous motor, copper wires, built-in thermal protector, fully closed fan cooling, continuous running
- Protection: IPX4 or IP22
- Insulation: B
- NSK bearing
- Timing and temperature constant operation



Performance Data

Model		Electrical Data				Max. head (m)	Max. flow (m ³ /h)	Whole lift (m)	G (mm)	Outer Box		20" Loading Qty (pcs)
Single-Phase	Three-Phase	Input Power P _i (W)	Current (A)	Capacitor						G.W. (kg)	Dim (L × W × H)	
				μF	Vc							
CPH10-40F	-	240	0.9	8	450	5.5	9	0~5.5	G1 1/2	8.9	290 × 280 × 220	1600
CPH12-50F	-	300	1.3	10	450	6	15	0~6	G2	12.8	330 × 325 × 225	1190
CPH25-40F	-	450	1.8	10	450	15	9	0~15	G1 1/2	10.3	330 × 280 × 225	1360
CPH25-50F	-	410	1.87	12	450	8	18	0~8	DN50(G2")	19	310 × 195 × 350	1188
CPH40-50F	-	900	2.95	25	450	17	21	0~17	DN50(G2")	26.5	315 × 235 × 430	810
CPH110-50F	-	1500	7.02	35	450	20	24	0~20	DN50(G2")	28	315 × 235 × 430	810
-	CPHS150-40F	2100	3.4	/	/	25	30	0~25	DN40(G1.5")	37.5	500 × 350 × 280	528
-	CPHS220-40F	2900	4.8	/	/	30	36	0~30	DN40(G1.5")	40	500 × 350 × 280	528

HBS-12



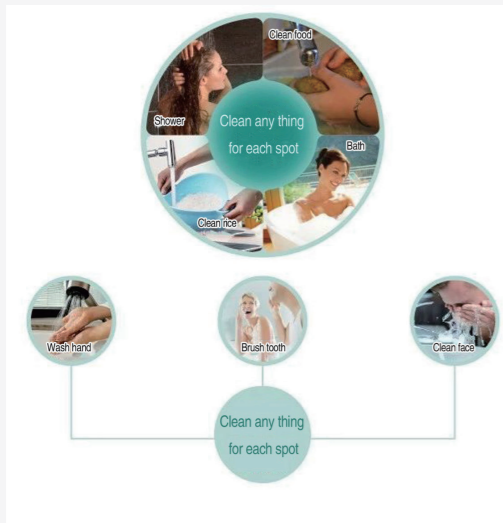





- Offering the warm water in any time when you open the tap, which have your life comfortable and intelligent!
- Saving the cooling water every drop, which have us join the action to protect the water resource!
- Offering big water when the pressure is lower.



Performance Data

Item No.	Pipe size (mm)	Shift	Max. Head (m)	Max. Head tolerance(-8%) (m)	Dated. Flow (L/min)	Dated. Head (m)	Dated head tolerance(-8%) (m)	Max. Input Power (W)	Pump efficiency (%)	Efficiency tolerance(-7%) (%)
HBS-12	15	II	12	11.01	9.1	10	9.2	55	27	25.1
		I	10	9.2	4	10	9.2	35	/	/



No.	Unions On Request	Material	Picture	Models
	Standardized			
1	3/4" to 1/2"	Brass or Cast Iron		XP415-4/6-130, ZP15-9-160, ZPS15-9-140, XPS15-4/6-130 XPS15-9-140
2	1" to 1/2"	Brass or Cast Iron		APS20-4/6-130, XPH20-4/6-130, XPS20-12-180 XPS20-4/6-130, XPS20-12-180
3	1 1/2" to 1"	Cast Iron		APS25-4/6-130, APS25-4/6-180, XPS25-4/6-130 XPS25-4/6-180, XPH25-4/6-130, XPH25-4/6-180 XPS25-8-180, XPS25-12-180, XP25-12-200, XP25-16-220
4	2" to 1 1/4"	Cast Iron		APS32-4/6-180, XPS32-4/6-180, XPH32-4/6-180, XPS32-8-180, XP32-9/12-220, XP32-16/18-230
5	(DN40)	Cast Iron		XP40-9F-250, XP40-12F-250 XP40-16F-250, XP40-18F-250
6	(DN50)	Cast Iron		XP50-9F-280, XP50-12F-280 XP50-16F-280
7	(DN65)	Cast Iron		XP65-9F-300, XP50-12F-300
8	Support	Stainless steel		XPS/XPH15/20/25/32-4/5/6, Z(X)PS15-9
9	Support	Stainless steel		X(Z)PS20-12-180, XPS25-8/12-180, XPS32-8-180

